

Hammerhead Rave 150

Parts Manual



This Vehicle is designed for off-road use only

FIG.1

CYLINDER HEAD ASSY.

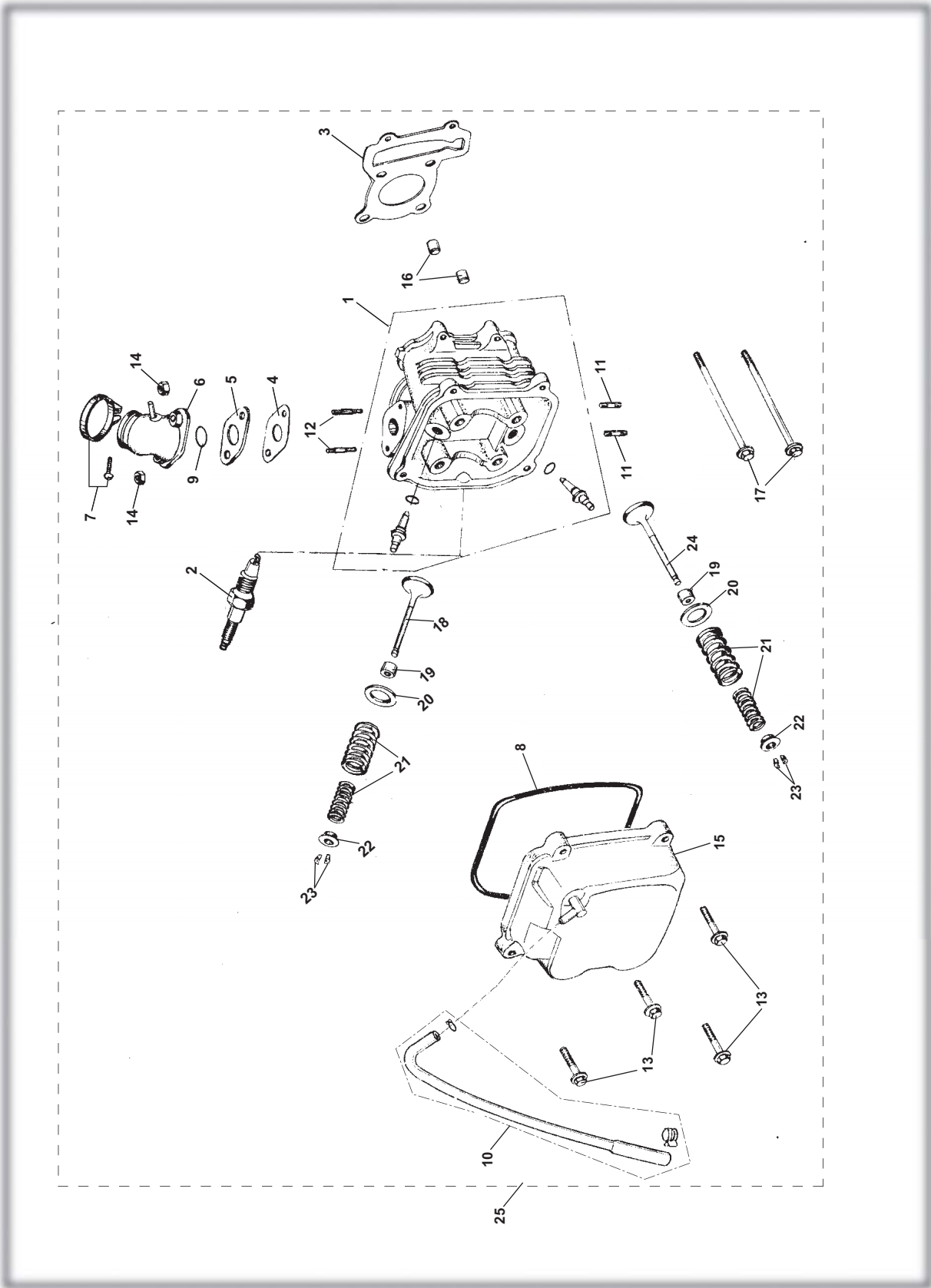

CYLINDER ASSY.

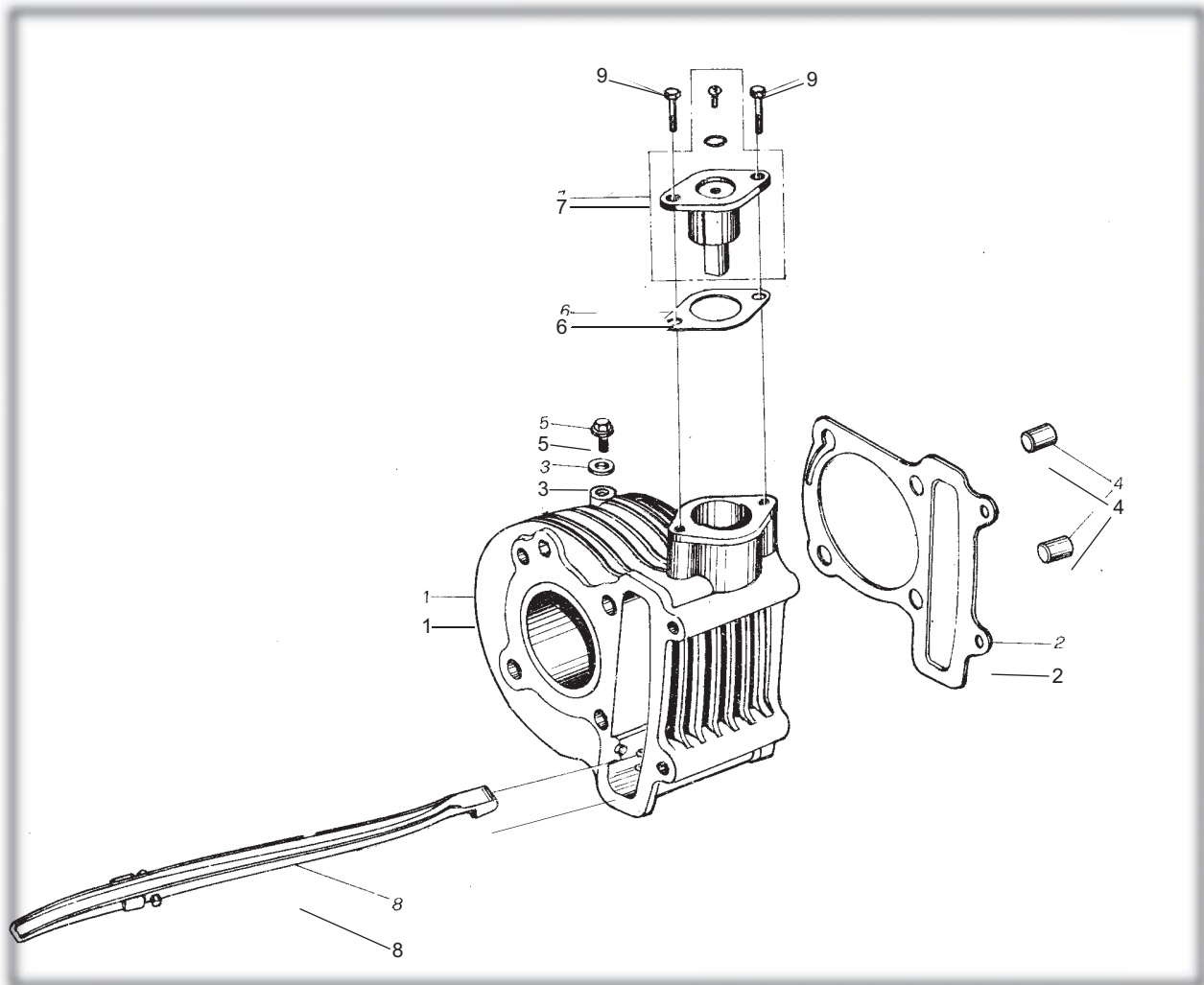

CYLINDER ASSY.				
REF NO.	PART NO.	DESCRIPTION	REGD NO.	
1	M150-1002200	CYLINDER COMP.	1	
2	M150-1002001	CYLINDER GASKET	1	
3	90442-06000-KAT	WASHER SEALING 6	1	
4	M150-1001007	DOWEL PIN 10X16	2	
5	96001-06012-KAT	FLANGE BOLT M6X12-ZN. D	1	
6	M150-1002002	GASKET TENSIONER LIFTER	1	
7	M150-1002100	TENSIONER LIFTER ASSY.	1	
8	M150-1002300	CAM CHAIN GUIDE COMP.	1	
9	96001-06020-KAT	FLANGE BOLT 6X20	2	

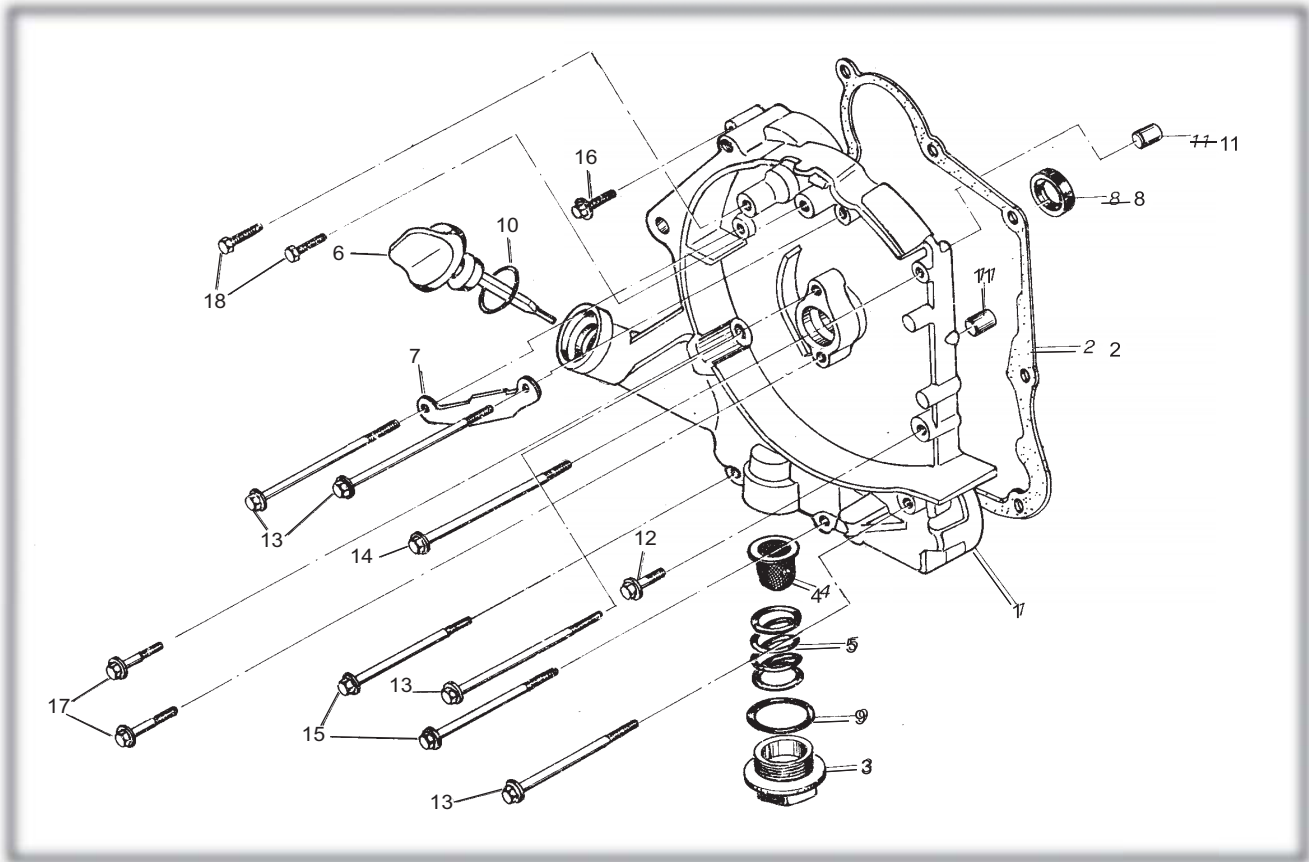
CRANKCASE ASSY. (1)**CRANKCASE ASSY.(1)**

REF NO.	PART NO.	DESCRIPTION	REGD NO.	
1	M150-1003101-B	R CRANKCASE COVER COMP.	1	
2	M150-1003013	CRANKCASE COVER GASKET	1	
3	M150-1003104	CAP TAPPET ADJUSTING HOLE	1	
4	M150-1003120	OIL FILTING SCREEN	1	
5	M150-1003102	OIL FILTING SCREEN SPRING	1	
6	M150-1003105	OIL LEVEL GAUGE	1	
7	M150-1003006	AC GENERATOR CORD CLAMPER	1	
8	M150-1003110	OIL SEAL 19.8X30X5	1	
9	M150-1003103	O-RING 30.8X3	1	
10	M150-1003307	O-RING 18X3	1	
11	M150-1003005	DOWEL PIN 8X14	2	
12	96001-06032-KAT	FLANGE BOLT M6X28	1	
13	M150-1003012	FLANGE BOLT M6X95	4	
14	M150-1003007	FLANGE BOLT M6X100	1	
15	M150-1003008	FLANGE BOLT M6X110	2	
16	M150-1003034	FLANGE BOLT M6X35	1	
17	M150-1003106	FLANGE BOLT M6X20	2	
18	92101-05012-OH	HEX BOLT M5X12-ZN.D	2	

FIG.4

CRANKCASE ASSY. (2)

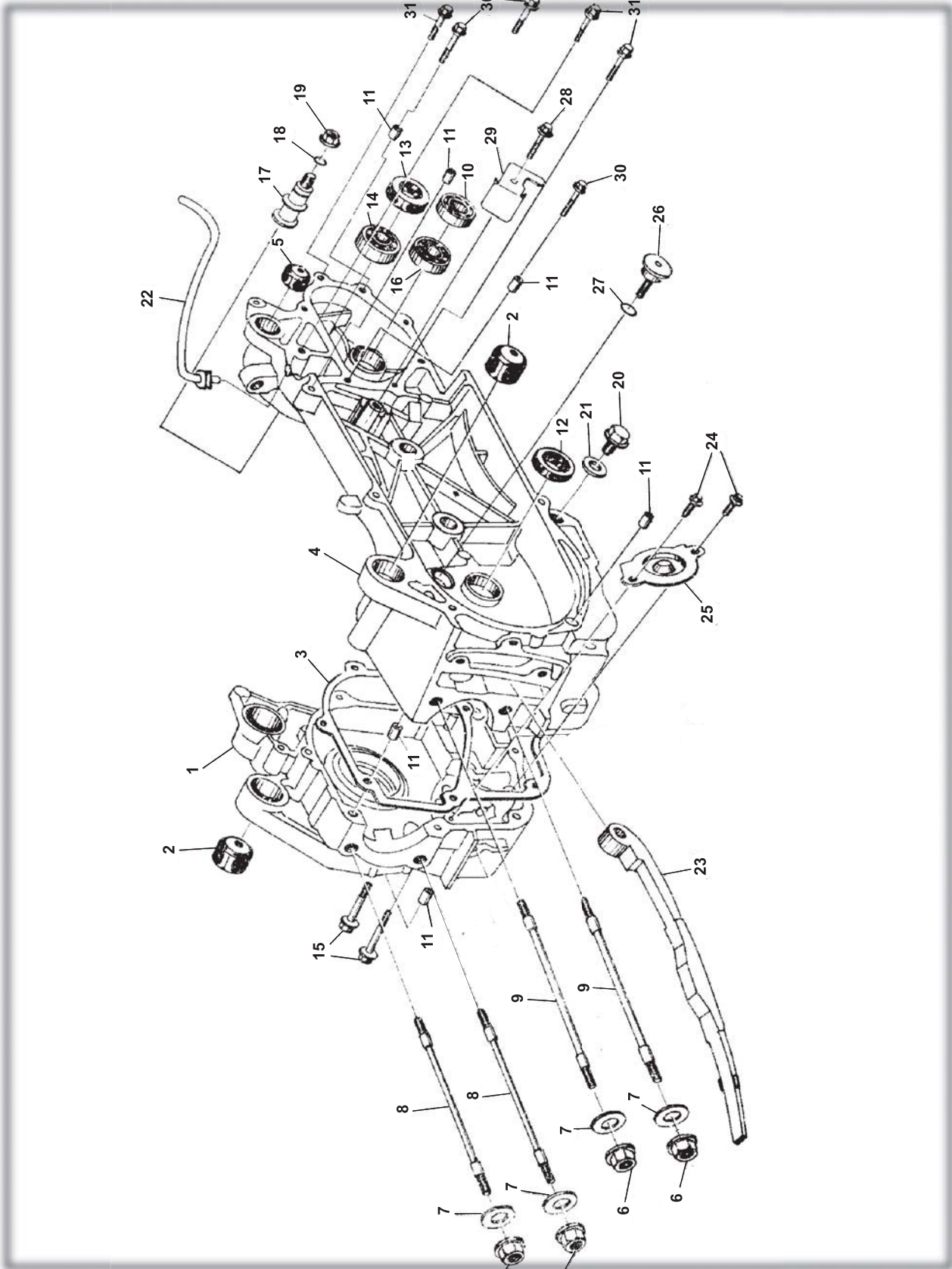

CRANKCASE ASSY.				
REF NO.	PART NO.	DESCRIPTION	REGD NO.	
1	M150-1003210-B	CRANKCASE ASSY. R	1	
2	M150-1003320	ENGINE HANGER RUBBER BUSH	2	
3	M150-1003014	CRANKCASE GASKET	1	
4	M150-1003310	CANKCASE ASSY. L	1	
5	M150-1003330	RR CUSHION UNDER RUBBER BUSH	1	
6	M150-1003003	FLANGE NUT M8	4	
7	M150-1003004	WASHER ϕ 8	4	
8	M150-1003001	STUD BOLT M8X187.5	2	
9	M150-1003002	STUD BOLT M8X195.5	2	
10	91004-E6002-KAT	RADIAL BALL BEARING E6002	1	
11	M150-1003005	DOWEL PIN 8X14	6	
12	M150-1003110	OIL SEAL 19.8X30X5	1	
13	M150-1003340	OIL SEAL 27X42X7	1	
14	91004-E6004-2RS	RADIAL BALL BEARING E6004-2RS	1	
15	M150-1003032	FLANGE BOLT M6X50	2	
16	91004-E6301-KAT	RADIAL BALL BEARING E6310	1	
17	M150-1003015	BRAKE SHOE ANCHOR PIN	1	
18	M150-1003016	OIL SEAL 7.5X15	1	
19	M150-1003600	FLANGE NUT M8	1	
20	M150-1003018	DRAIN PLUG BOLT M12	1	
21	M150-1003019	DRAIN PLUG WASHER ϕ 12	1	
22	M150-1003400	BREATHER TUBE	1	
23	M150-1003500	CAM CHAIN TENSIONER	1	
24	M150-1003203	FLANGE BOLT M6X12	2	
25	M150-1003202	OIL SEPARATOR	1	
26	M150-1003022	CAM CHAIN TENSIONER PIVOT	1	
27	M150-1003023	OIL SEAL 15.2X12	1	
28	96001-06014-KAT	FLANGE BOLT M6X14	1	
29	M150-1003021	KICK RETURN STOPPER PLATE	1	
30	M150-1003009	FLANGE BOLT M6X35	3	
31	M150-1003011	FLANGE BOLT M6X25	3	

CRANKSHAFT CON'ROD & PISTON ASSY.

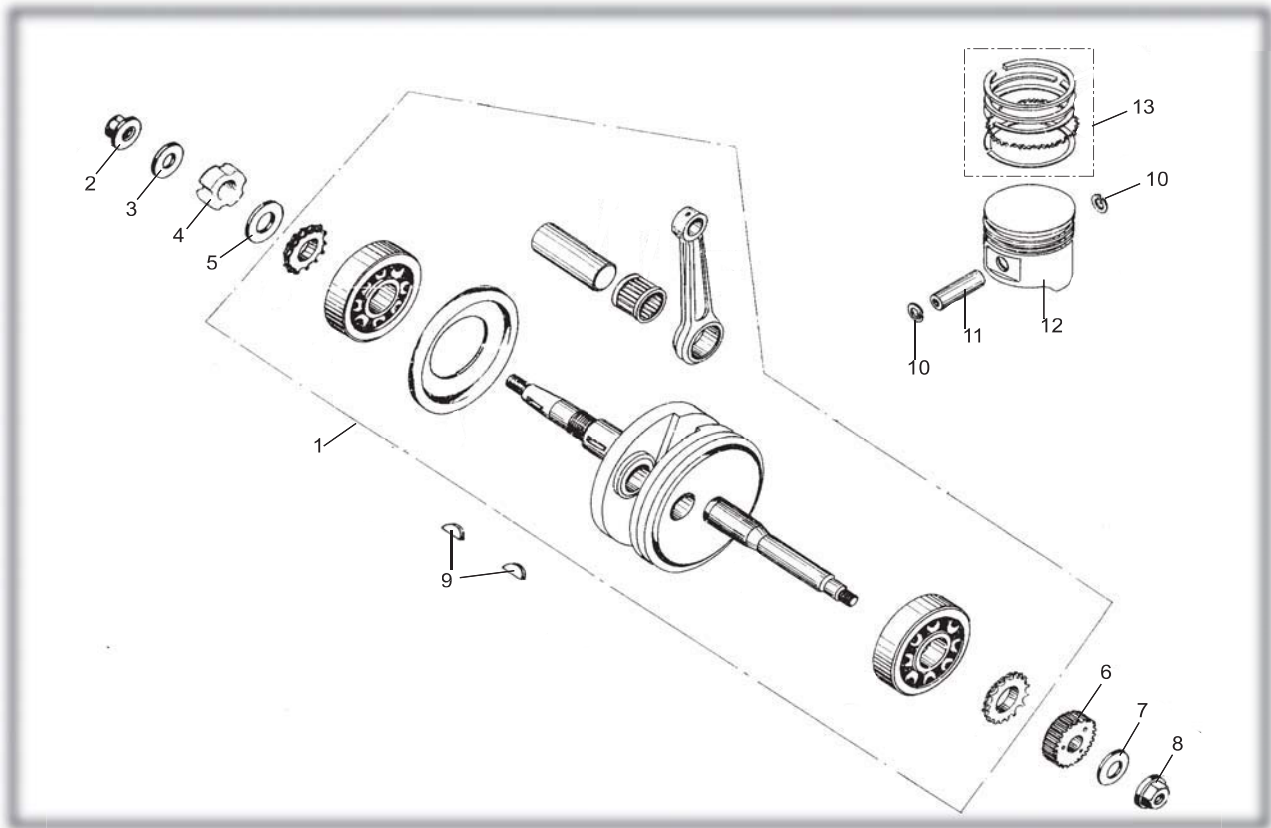

CRANKSHAFT CON'ROD & PISTON ASSY.				
REF NO.	PART NO.	DESCRIPTION	REGD NO.	
1	M150-1004100	CRANKSHAFT & CONROD ASSY.	1	
2	M150-1004007	NUT M12X1.25	1	
3	M150-1004011	WASHER 12-149HV 12-140HV	1	
4	M150-1004009	LOCKING NUT	1	
5	M150-1004013	WASHER	1	
6	M150-1004012	KICK DRIVE GEAR	1	
7	M150-1040005	WASHER $\Phi 12$	1	
8	M150-1004008	NUT M12	1	
9	M150-1004002	WOODRUFF KEY	2	
10	M150-1004003	PISTON PIN CLIP	2	
11	M150-1004006	PISTON PIN	1	
12	M150-1004001	PISTON	1	
13	M150-1004200	PISTON RING SET	1	

CAMSHAFT ASSY.

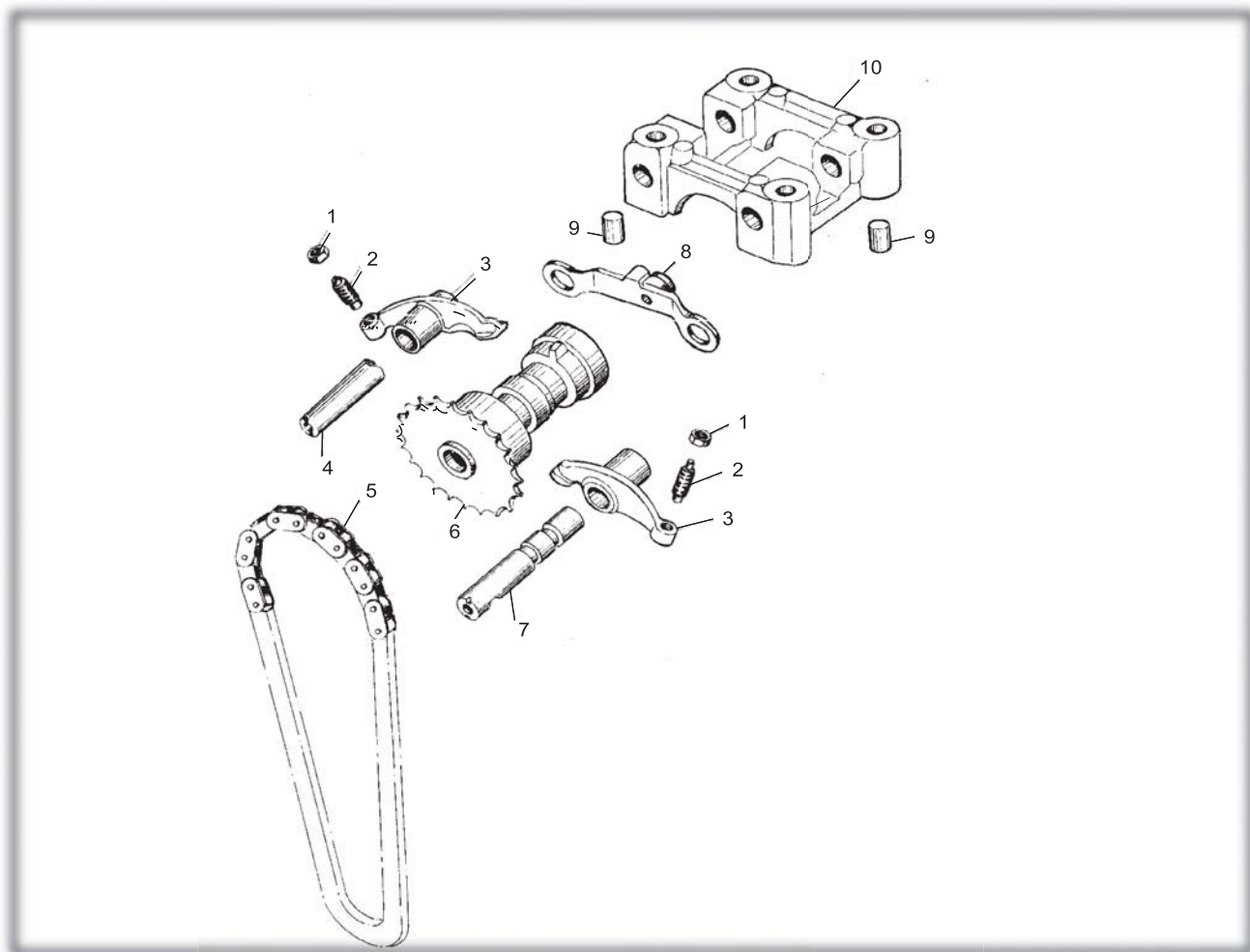

CAMSHAFT ASSY.				
REF NO.	PART NO.	DESCRIPTION	REGD NO.	
1	M150-1005004	TAPPET ADJUSTING NUT	2	
2	M150-1005003	TAPPET ADJUSTING SCREW	2	
3	M150-1005002	VALVE ROCKER ARM	2	
4	M150-1005005	EX ROCKER ARM SHAFT	1	
5	M150-1005400	CAMSHAFT CHAIN	1	
6	M150-1005300	CAMSHAFT COMP. 16T	1	
7	M150-1005200	IN ROCK ARM SHAFT COMP.	1	
8	M150-1005100	STOPPER PLATE COMP.	1	
9	M150-1001007	DOWEL PIN 10X16	2	
10	M150-1005001	CAMSHAFT HOLDER	1	

LEFT COVER ASSY.

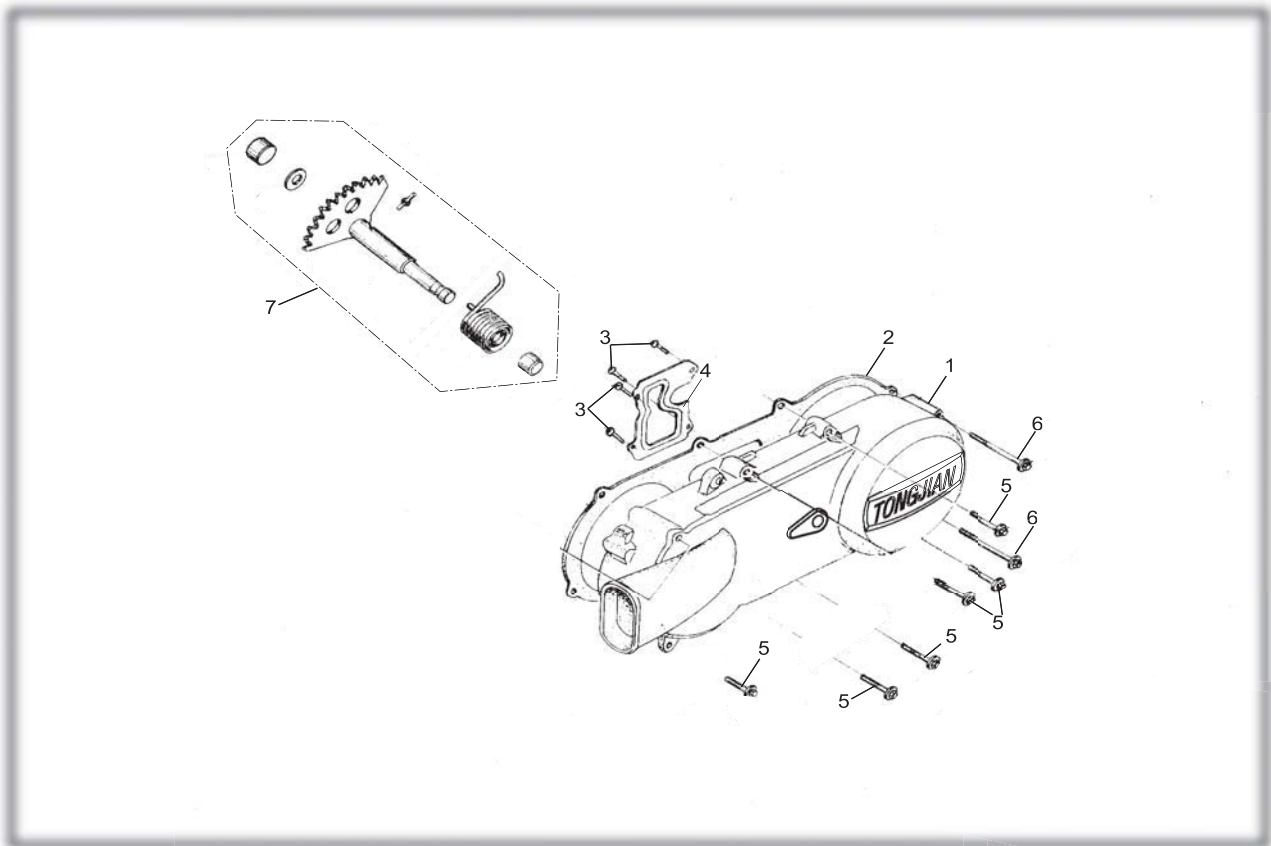

LEFT COVER ASSY.				
REF NO.	PART NO.	DESCRIPTION	REGD NO.	
1	M150-1008101	COVER L	1	
2	M150-1008005	L COVER GASKET	1	
3	93903-00428-KAT	TAPPING SCREW ST4.2X8-F-H	4	
4	M150-1008102	L COVER PLATE	1	
5	M150-1003034	FLANGE BOLT M6X40	6	
6	M150-1008006	FLANGE BOLT M6X65	2	
7	M150-1008200	KICK STARTER ASSY. SPINDLE COMP.	1	

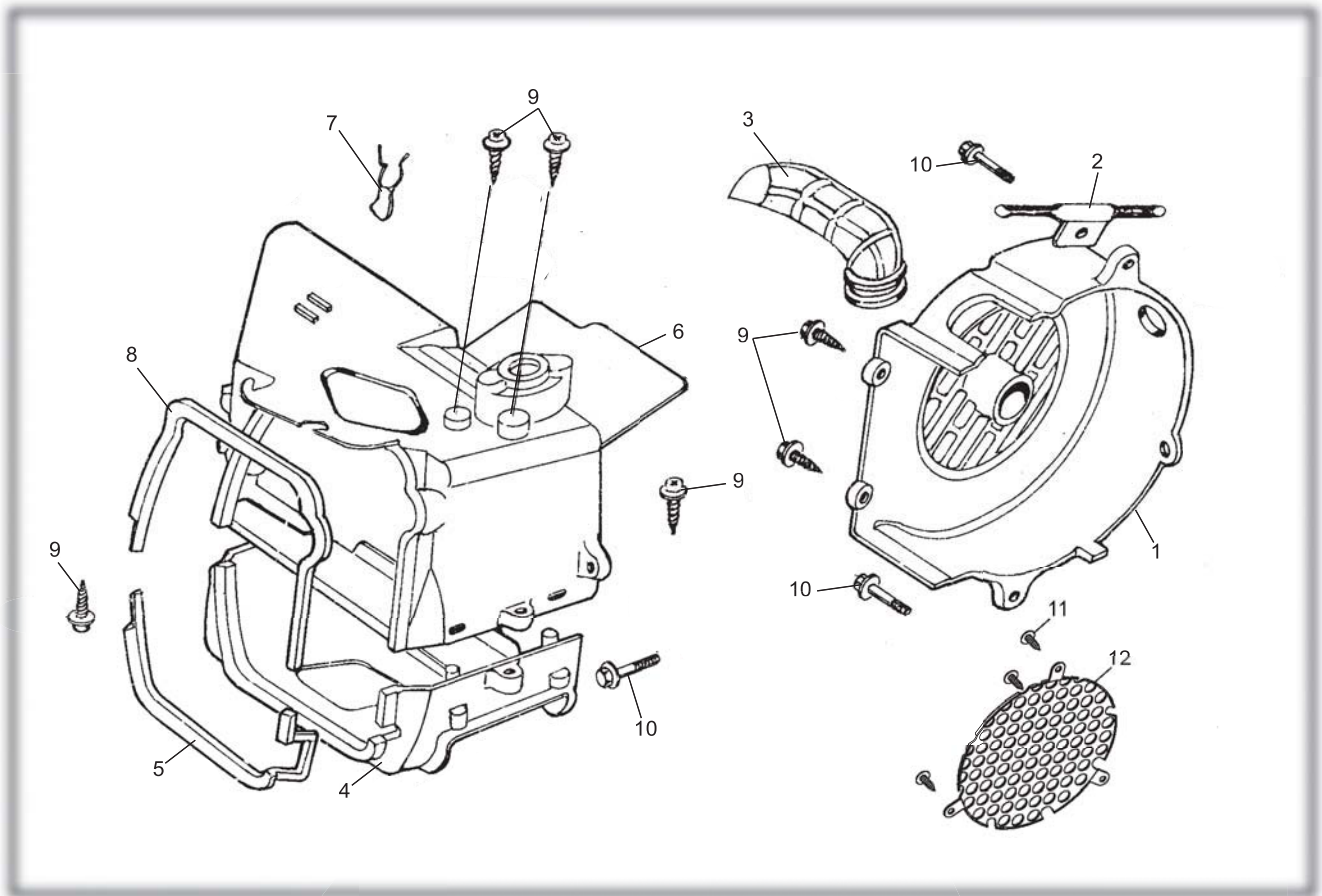
FAN COVER AND SHROUD ASSY.**FAN COVER AND SHROUD ASSY.**

REF NO.	PART NO.	DESCRIPTION	REGD NO.	
1	M150-1009410	FAN COVER COMP.	1	
2	M150-1009002	STARTER CABLE CLAMPER	1	
3	M150-1009401	FAN SHROUD COOLING DUCT	1	
4	M150-1009301	LOWER SHROUD	1	
5	M150-1009302	LOWER SHROUD SEAL	1	
6	M150-1009110	UPPER SHROUD COMP.	1	
7	M150-1009103	HIGH TENSION CORD CLIP	1	
8	M150-1009102	UPPER SHROUD SEAL	1	
9	M150-1009402	SCREW ST4.8X16-F	6	
10	M150-1003075	BOLT M6X25	3	
11	ST3.5X13 GB845	SCREW ST3.5×13-F	3	
12	8.020.179	DUST COVER	1	

OIL PUMP ASSY.

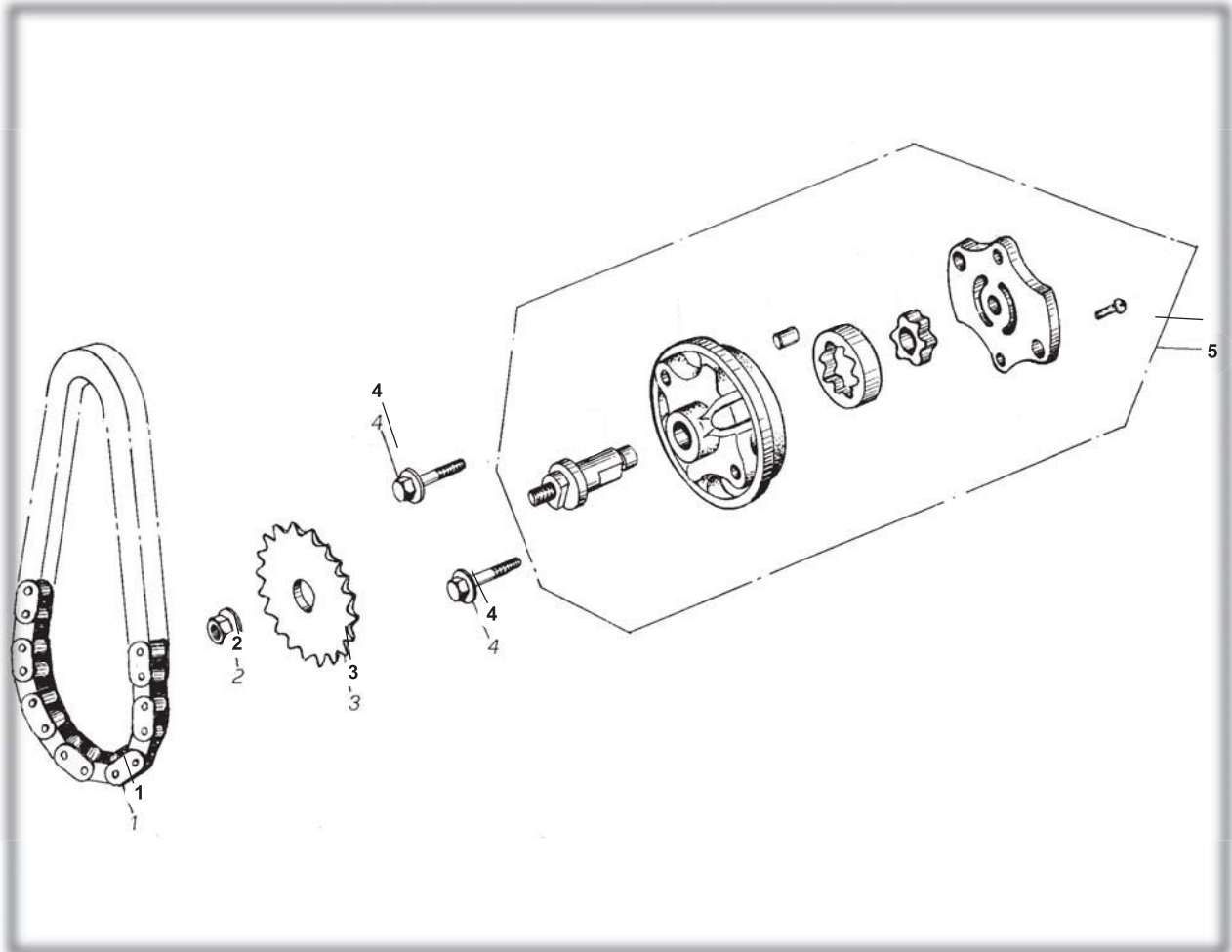

OIL PUMP ASSY.				
REF NO.	PART NO.	DESCRIPTION	REGD NO.	
1	M150-1021000	CHAIN OIL PUMP	1	
2	M150-1020002	NUT FLANGE M6	1	
3	M150-1020001	SPROCKET OIL PUMP DRIVEN	1	
4	M150-B-1003075	BOLT M6X25	2	
5	M150-1022000	OIL PUMP SUB ASSY.	1	

DRIVEN PULLEY AND CLUTCH SUBASSY.

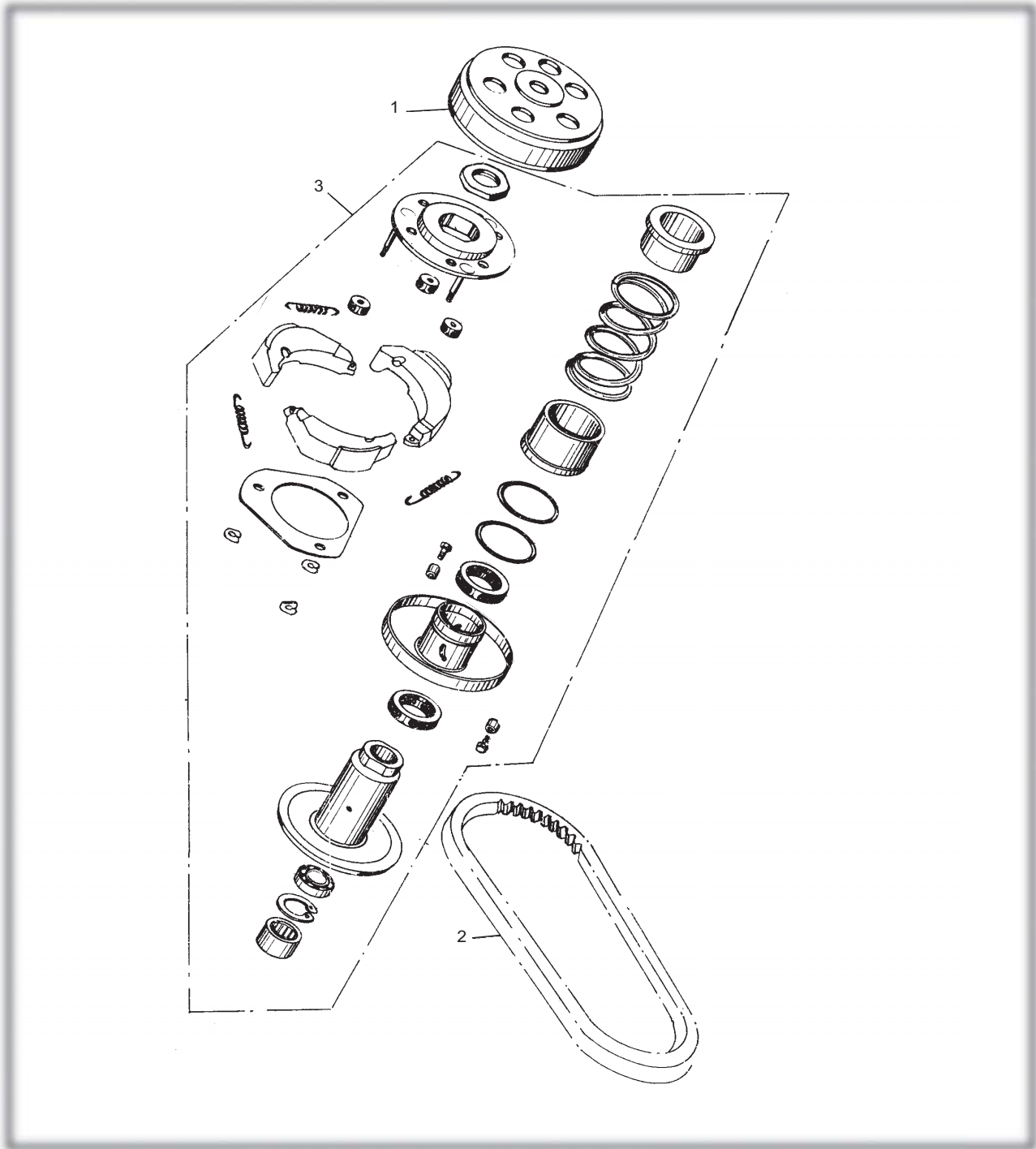

DRIVEN PULLEY AND CLUTCH SUBASSY.

REF NO.	PART NO.	DESCRIPTION	REGD NO.	
1	M150-1032000	CLUTCH ASSY. OUTER	1	
2	M150-1033000	DRIVE BELT	1	
3	M150-1031000	DRIVEN PULLEY ASSY.	1	

TRANSMISSION ASSY.

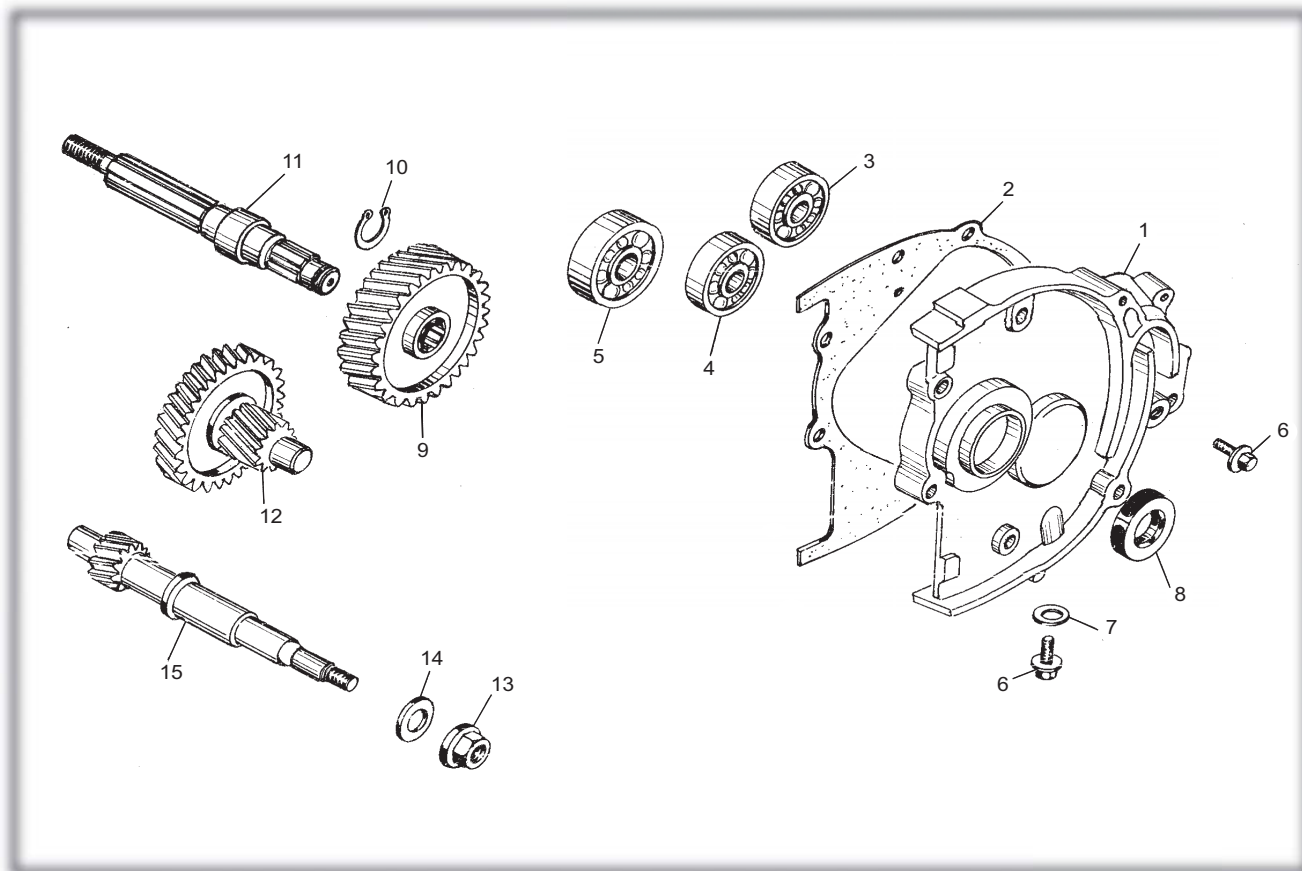

TRANSMISSION ASSY.				
REF NO.	PART NO.	DESCRIPTION	REGD NO.	
1	M150-1040001	TRANSMISSION COVER	1	
2	M150-1041000	TRANSMISSION COVER GASKET	1	
3	91004-E6203-KAT	RADIAL BALL BEARING E6203	1	
4	91004-E6202-KAT	RADIAL BALL BEARING E6202	1	
5	91004-E6204-KAT	RADIAL BALL BEARING E6204	1	
6	M150-1040008	SPECIAL BOLT M8X12	2	
7	M150-1040002	WASHER Φ8	1	
8	M150-1042000	OIL SEAL 20X32X6	1	
9	M150-1040004	FINAL GEAR	1	
10	94510-20000	EXTERNAL CIRCLIP 20	1	
11	M150-1040003	FINAL SHAFT	1	
12	M150-1043000	COUNTER SHAFT COMP.	1	
13	M150-1040007	COMPRESSOR FLANGE NUT M12	1	
14	M150-1040005	WASHER Φ12	1	
15	M150-1040006	DRIVE SHAFT	1	

ELECTRIC SYSTEM

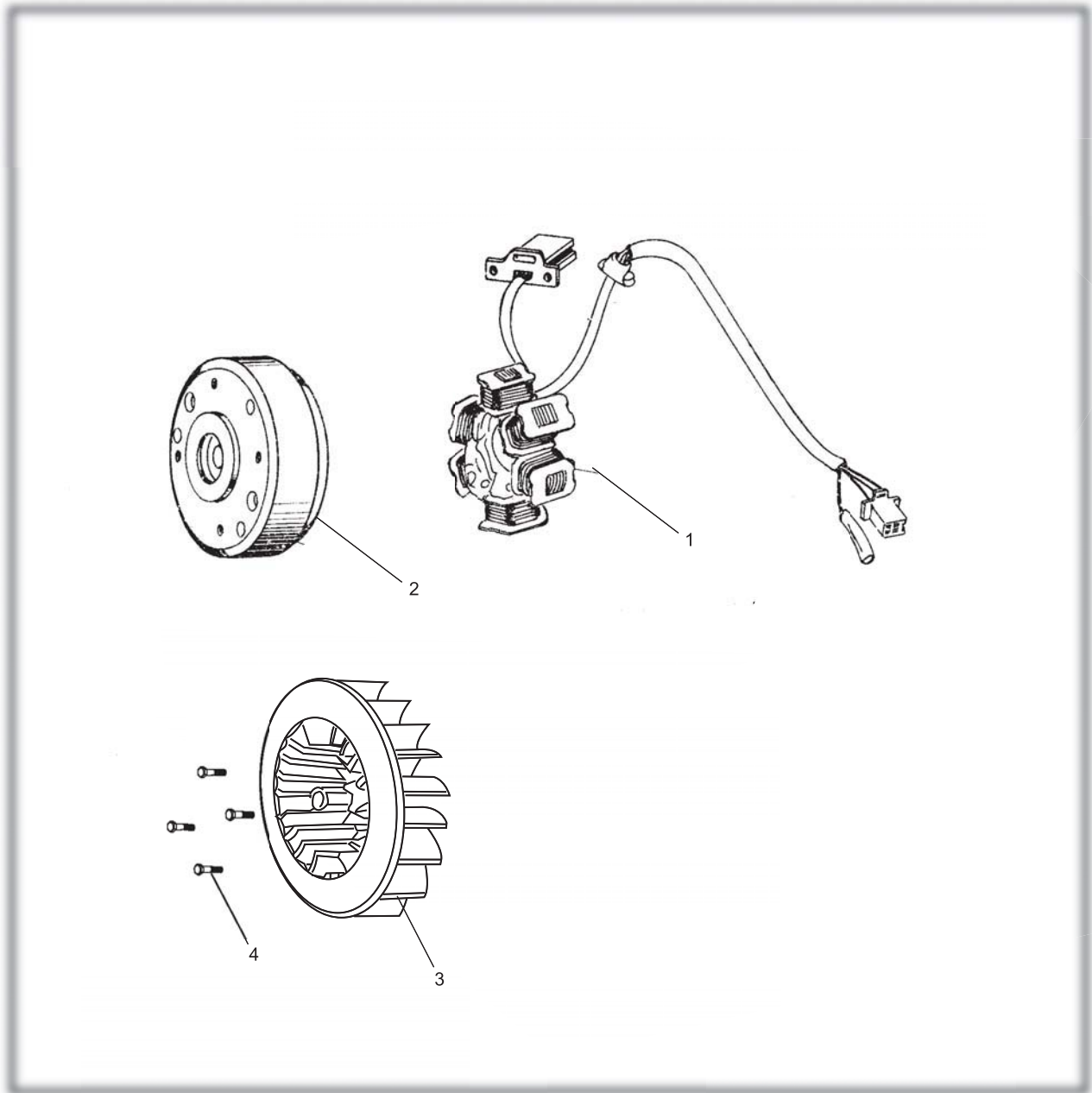

ELECTRIC SYSTEM

REF NO.	PART NO.	DESCRIPTION	REGD NO.	
1	M150-1051200-8	STATOR COMP.	1	
2	M150-1051100	FLYWHEEL COMP.	1	
3	M150-1051100-3	COOLING FAN COMP.	1	
4	M150-1051100-4	FLANGE BOLT M6x18	4	

ELECTRIC STARTER ASSY.

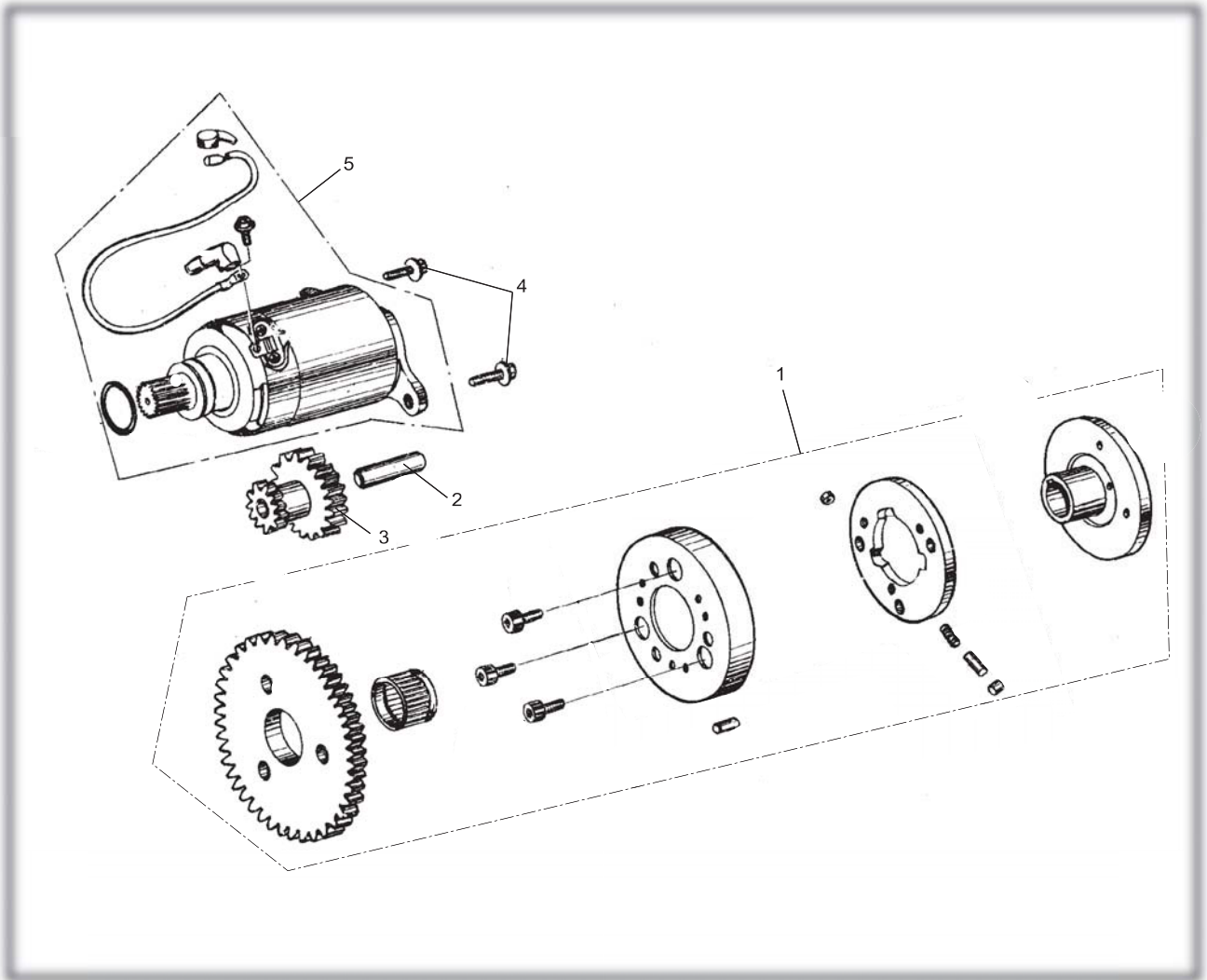

ELECTRIC STARTER ASSY.

REF NO.	PART NO.	DESCRIPTION	REGD NO.	
1	M150-1060001	FLANGE STARTING CLUTCH	1	
2	M150-1060002	STARTER REDUCTION GEAR SHAFT	1	
3	M150-1060003	STARTER REDUCTION GEAR	1	
4	M150-1060005	FLANGE BOLT M6X16	2	
5	M150-1064000	STARTER MOTOR ASSY.	1	

DRIVE PULLEY SUBASSY.

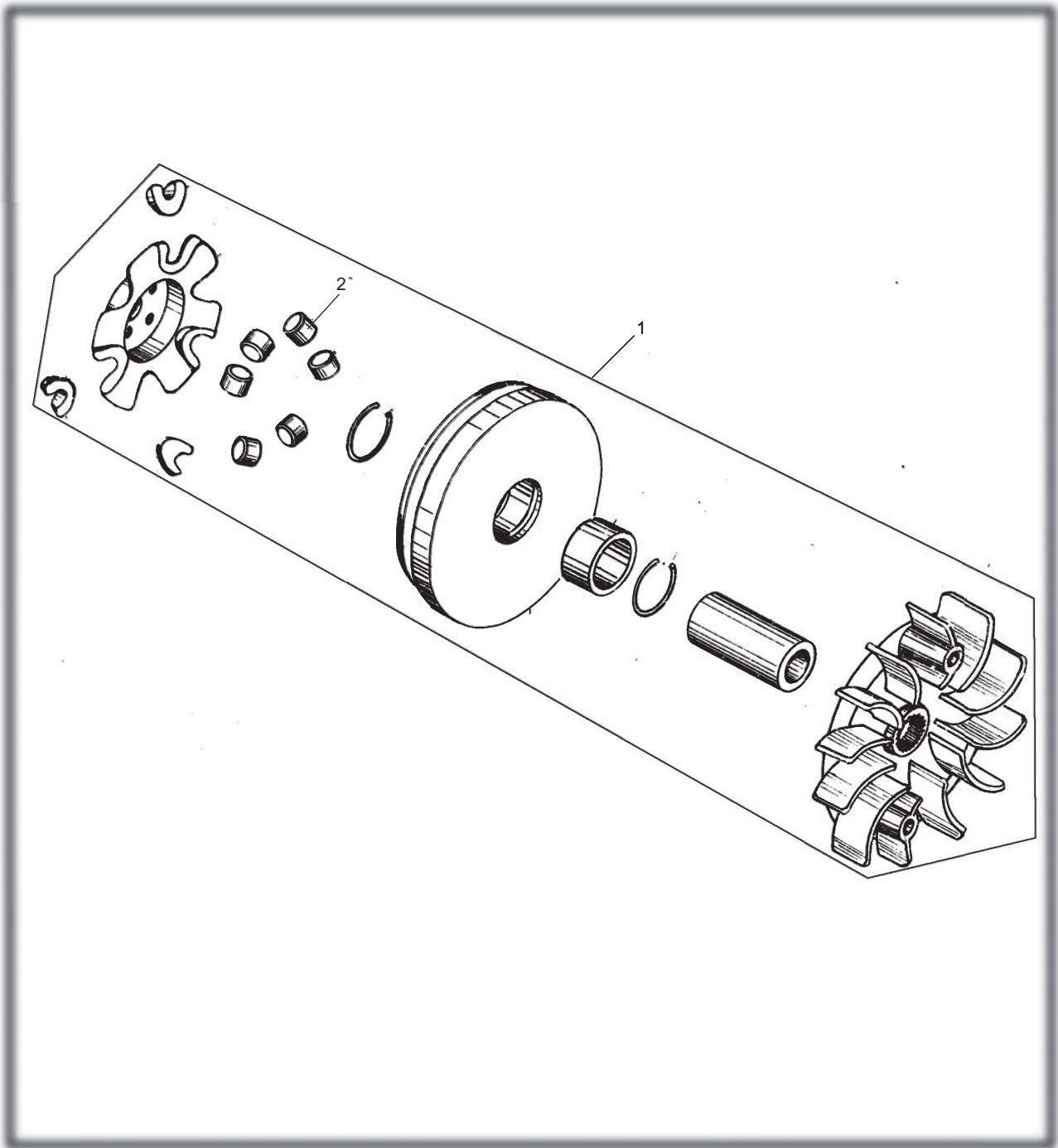

DRIVE PULLEY SUBASSY.

REF NO.	PART NO.	DESCRIPTION	REGD NO.	
1	M150-1071000	MOVABLE DRIVE PULLEY ASSY.	1	
2	M150-10710002	ROYER	6	

FIG.15

CARBURETOR

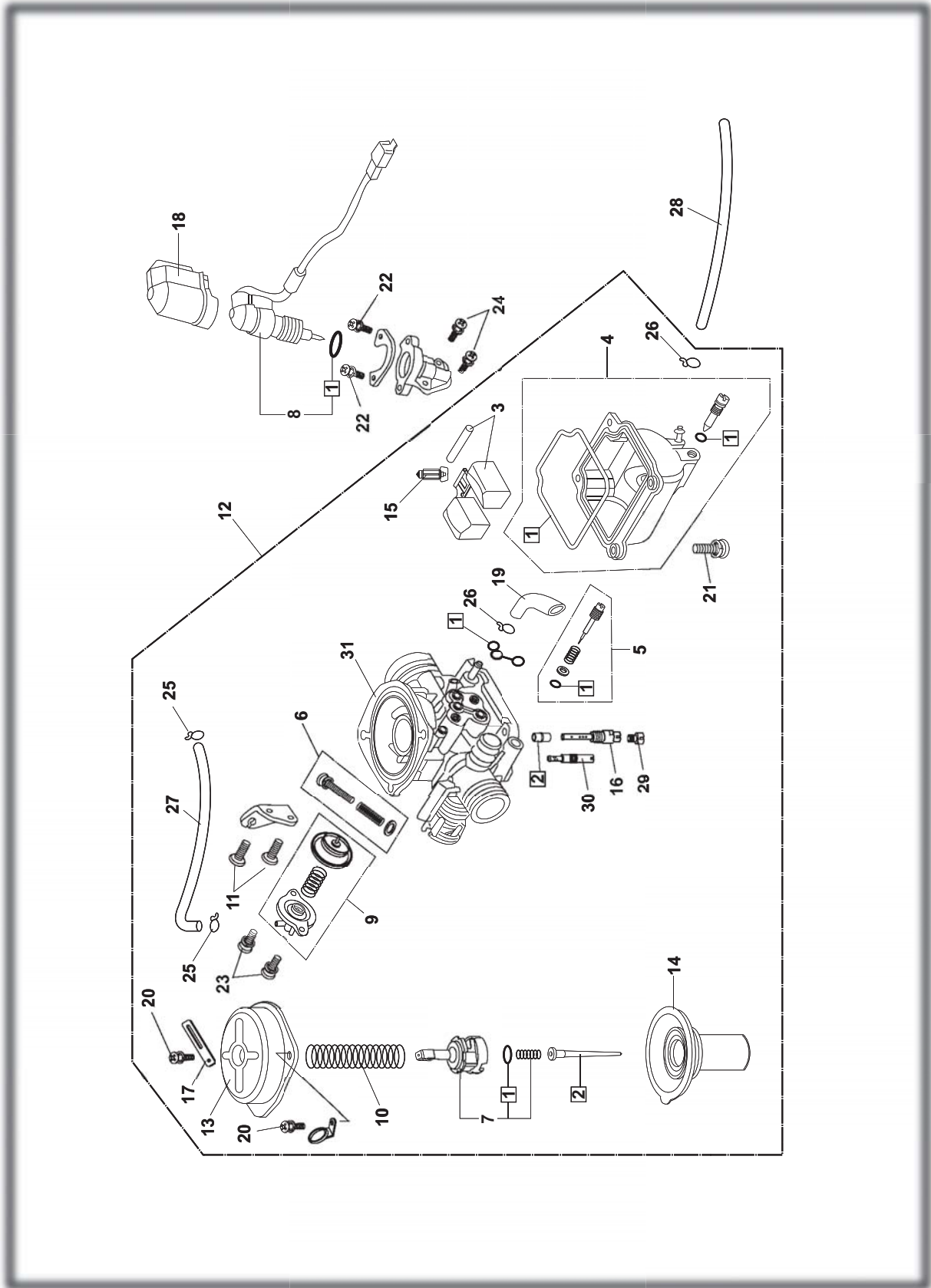

CARBURETOR				
REF NO.	PART NO.	DESCRIPTION	REGD NO.	
1	16010-KAT-901	GASKET SET A	1	
2	16012-KAT-903	JET NEEDLE SET	1	
3	16013-KAT-904	FLOAT SET	1	
4	16015-KAT-905	FLOAT CHAMBER SET	1	
5	16016-KAT-906	SCREW SET A	1	
6	16028-KAT-907	SCREW SET B	1	
7	16037-KAT-908	VALVE PLATE SET	1	
8	16046-KAT-909	AUTO BYSTARTER ASSY.	1	
9	16048-KAT-910	AIR CUT VALVE SET	1	
10	16050-KAT-911	COMPRESSION COIL SPRING	1	
11	16080-KJ9-003	PAN SCREW M5x12	1	
12	16100-KAT-913	CARBURETOR ASSY.	2	
13	16107-KAT-914	TOP	1	
14	16111-KAT-915	VACUUM PISTON COMP.	1	
15	16155-KAT-902	FLOAT VALVE COMP.	1	
16	16165-KAT-916	NEEDLE JET HOLDER	1	
17	16179-KAB-670	BINDER	1	
18	16190-GJ2-004	HOLDER CAP.	1	
19	95005-45270-50	TUBE	1	
20	93500-04008	PAN SCREW M4x8	1	
21	93500-04014-1H	PAN SCREW M4x14	2	
22	93892-04008-18	SCREW-WASHER M4x8	4	
23	93892-04010-18	SCREW-WASHER M4x10	2	
24	93892-05012-18	SCREW-WASHER M5x12	2	
25	95002-02079	TUBE CLIP (B7)	2	
26	95002-02089	TUBE CLIP (B8)	2	
27	95005-35200-21	TUBE 3.5x210	2	
28	16199-GT8-600	TUBE	1	
29	99101-GHB-0112	MAIN JET 112#	1	
30	99103-GY6-0350	SLOW JET 35#	1	
31	16100-KAT-923	CARBURETOR BODY	1	

Reverse Assembly

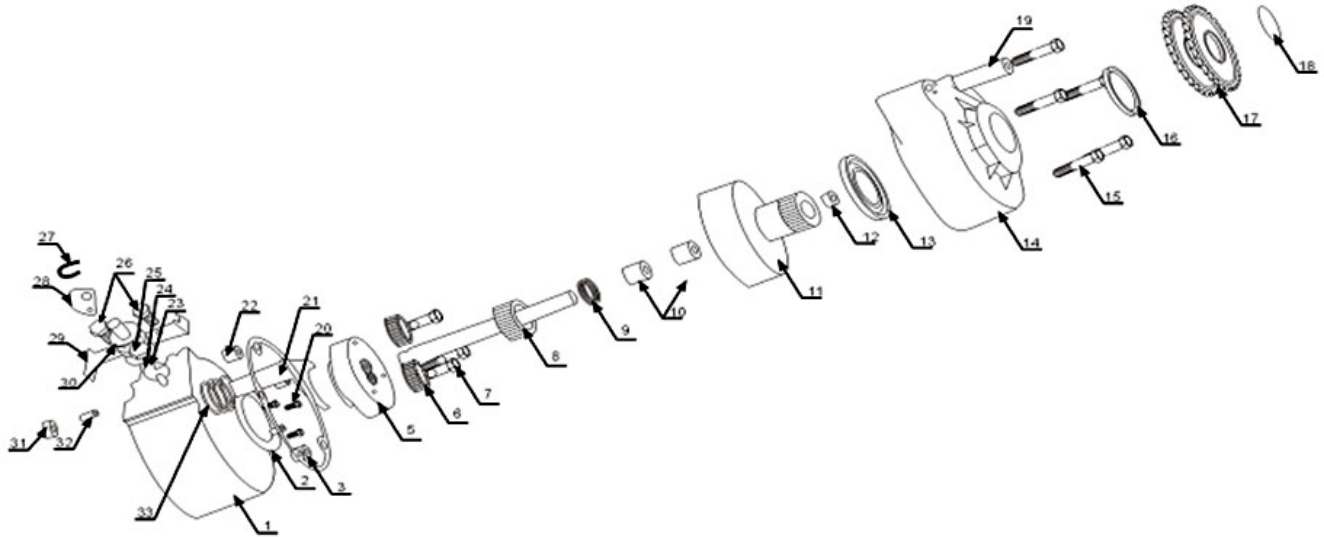

Ref. Num	Part Number	Description	Req. No.
1	GY150-401-0156	REVERSE GEAR PART OF CASE BODY	1
2	GY150-401-0157	RING GEAR OF REVERSE GEAR	1
3	GY150-401-0158	DOWEL PIN	2
4	GY150-401-0159	PAPER WASHER	1
5	GY150-401-0160	PLANET GEAR SEAT	1
6	GY150-401-0161	PLANET GEAR	3
7	GY150-401-0162	PLANET GEAR SHAFT	3
8	GY150-401-0163	OUTPUT SHAFT	1
9	GY150-401-0164	THRUST BEARING	1
10	GY150-401-0165	NEEDLE BEARING	2
11	GY150-401-0166	RING GEAR OF POSITIVE AND NEGATIVE ROTATION	1
12	GY150-401-0167	CHOKE PLUG	1
13	GY150-401-0168	BEARING	2
14	GY150-401-0169	SHELL OF REVERSE GEAR	1
15	GY150-401-0170	M10 COUPLING SCREW	5
16	GY150-401-0171	OIL SEAL	1
17	GY150-401-0172	SPROCKET WHEEL.DOUBLE ROW	1
18	GY150-401-0173	CIRCLIP	1
19	GY150-401-0174	BUSH ABSORBER	1
20	GY150-401-0175	SCREW COUNTERSUNK HEAD	4
21	GY150-401-0176	SHIFTING YOKE	1
22	GY150-401-0177	HOLLOW DOWEL PIN	2
23	GY150-401-0178	M8 SETSCREW	1
24	GY150-401-0179	O-RING	1
25	GY150-401-0180	M8 LICK NUT	1
26	GY150-401-0181	M6 COUPLING SCREW	2
27	GY150-401-0182	SPLIT CIRCLIP	1
28	GY150-401-0183	DRAGLINE DISC	1
29	GY150-401-0184	ADJUSTING HOLDER OF DRAGLING	1
30	GY150-401-0185	GEAR SHAFT OF GEAR SHIFT	1
31	GY150-401-0186	M6 LOCK SCREW	1
32	GY150-401-0187	M6 SETSCREW	1
33	GY150-401-0188	COMPRESSION SPRING OF SHIFTING YOKE	1

Frame Assembly

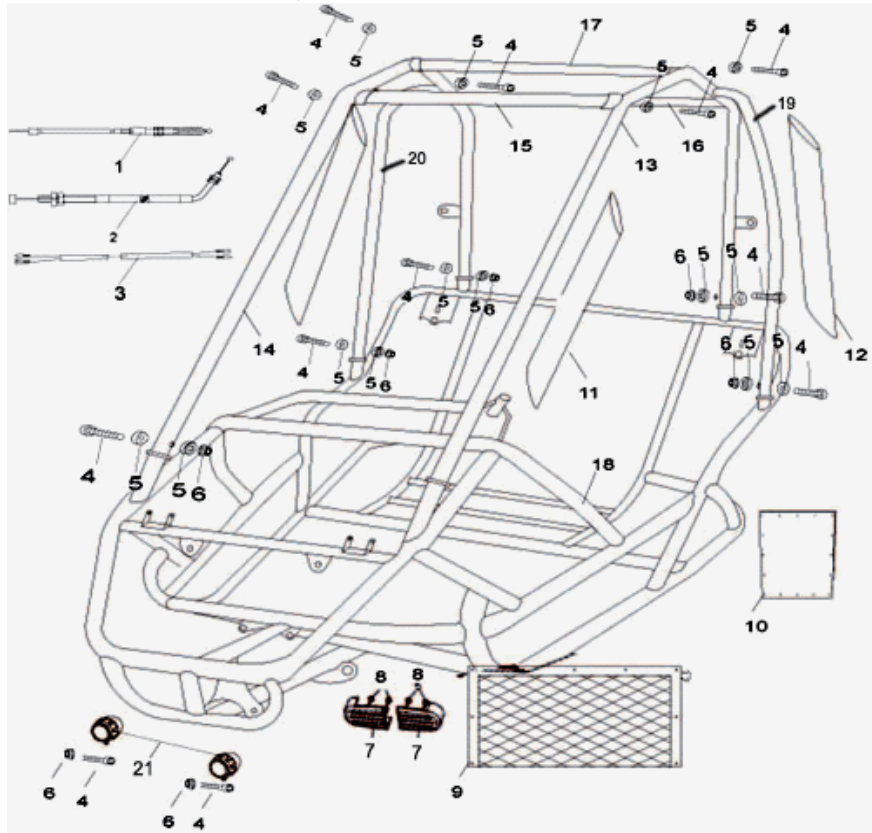

Ref. Num	Part Number	Description	Req. No.
1	6.000.034B	Throttle Cable	1
2	17-0700-00	Reverse Cable	1
3	16-0303-00	Front Electric Wire	1
4	9.908.055	ALLEN HEAD NUT M8*1.25*55	16
5	8.010.047	Concave Washer	20
6	9.220.008	LOCKING NYLON NUT M8	16
7	14548	Steering Chain Guard (Driver Side)	1
	14549	Steering Chain Guard (Passenger Side)	1
8	14421	Screw, M4 x 0.75 x 15	4
9	16-0802-00	Utility Canvas Net	1
10	16-0801-00	Canvas Top	1
11	16-0803-00	A-Pillar Foam Bar	2
12	16-0804-00	B-Pillar Foam Bar	2
13	16-0106-00	A-Pillar Brush Guard (driver Side)	1
14	16-0107-00	A-Pillar Brush Guard (Passenger Side)	1
15	16-0101-00	C-Pillar (front)	1
16	16-0108-00	C-Pillar (Rear)	1
17	16-0104-00	C-Pillar (middle)	1
18	16-0608-00	Frame	1
19	16-0103-00	B-Pillar (driver)	1
20	16-0109-00	B-Pillar (passenger)	1
21	13-0206-00	Head Light	2

Steering Assembly

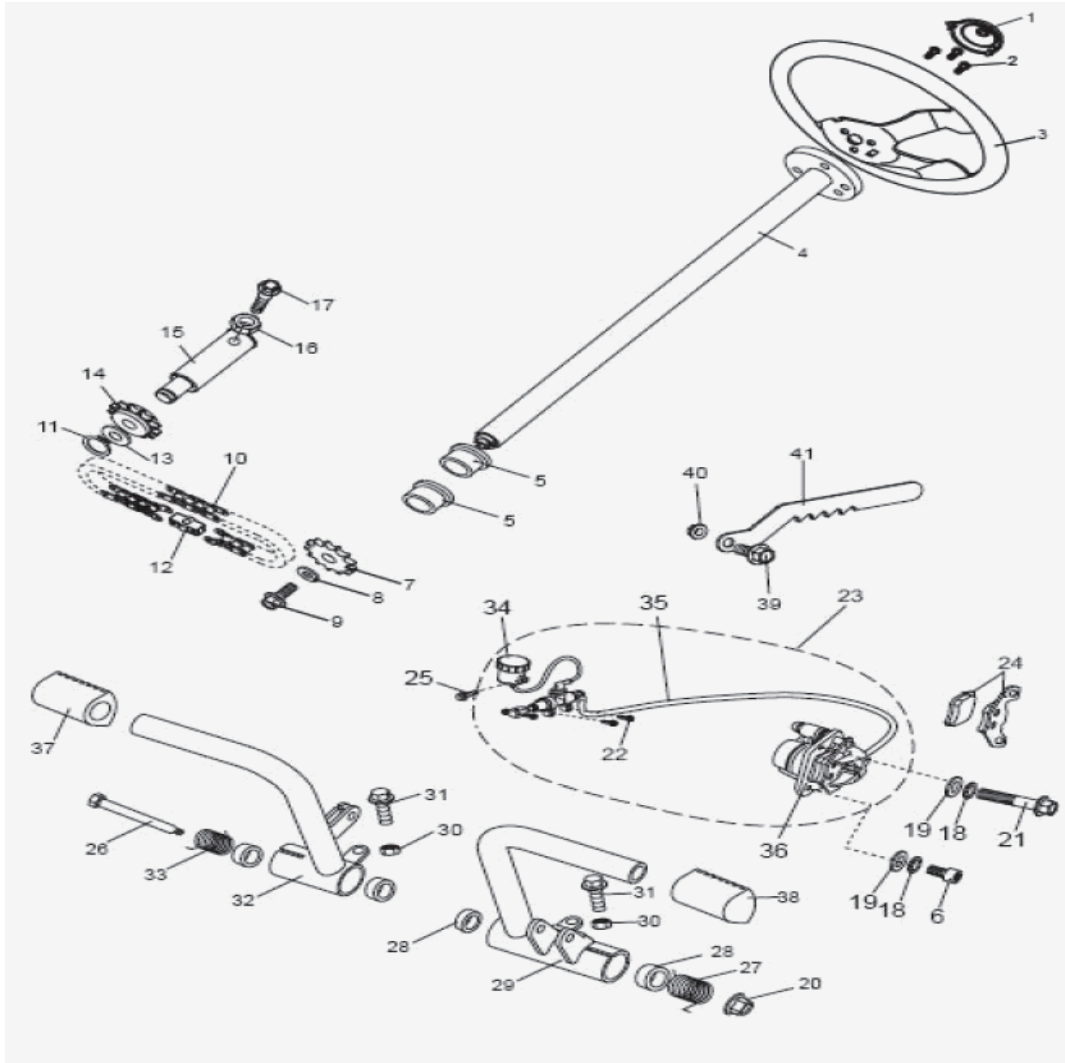

Ref. Num	PN	Description	Req. No.
1	14100	Cover, Steering Wheel	1
2	14237	Bolt, M6 x 12	3
3	14102	STEERING WHEEL	1
4	14385	STEERING-SHAFT	1
5	14104	Bushing, Steering Shaft	3
6	14432	Bolt, M8x 1.25 x 12	1
7	14518	Sprocket, 06B-13T steel	1
8	14293	Washer, M8 Flat	1
9	14435	Bolt, M8 x 1.25 x 22	1
10	14519	Chain, KMC 06B-1Rx82L	1
11	14520	Circlip, M15	1
12	14521	Link, Steering Chain	1
13	14550	Washer, 18x8.2x2.5	1
14	14522	Sprocket, 06B-13T-Plastic	1
15	14523	Shaft, Steering Adjustment	1
16	14088	Nut, M8 x 1.25 x 40 FHCS	1
17	14439	Bolt, M8x 1.25 x 40 FHCS	1
18	14238	Washer, M5 Flat Zn	2
19	14496	Washer, M5 Flat Zn	2
20	14088	Nut, M8 x 1.25 Locking Flange	1
21	14441	Bolt, M8 x 1.25 x 100 FHCS	1

Ref. Num	PN	Description	Req. No.
22	14430	Bolt, M6 x 1 x 25 FHCS	2
23	14386	Hydraulic Brake	1
24	14524	Brake Pad Kit	1
25	14426	Bolt, M6 x 1 x 14 FHCS	1
26	14442	Bolt, M8 x 1.25 x 145 HHCS	1
27	14120	Spring, Brake pedal	1
28	14119	Bushing, Pedal	4
29	14387	Brake Pedal	1
30	14236	Nut, M6 x 1	2
31	14430	Bolt, M6 x 1 x 25 FHCS	2
32	14388	Throttle Pedal	1
33	14113	Spring, Throttle Pedal	1
34	14389	Master Cylinder Cap	1
35	14525	Brake Hose	1
36	14390	Brake Caliper	1
37	14526	Throttle Pedal Cap	1
38	14527	Brake Pedal Cap	1
39	14437	Bolt, M8 x 1.25 x 25 FHCS	1
40	14088	Nut, M 8 x 1.25 Locking Flange	1
41	14528	Lever, Parking Brake	1

Front Suspension

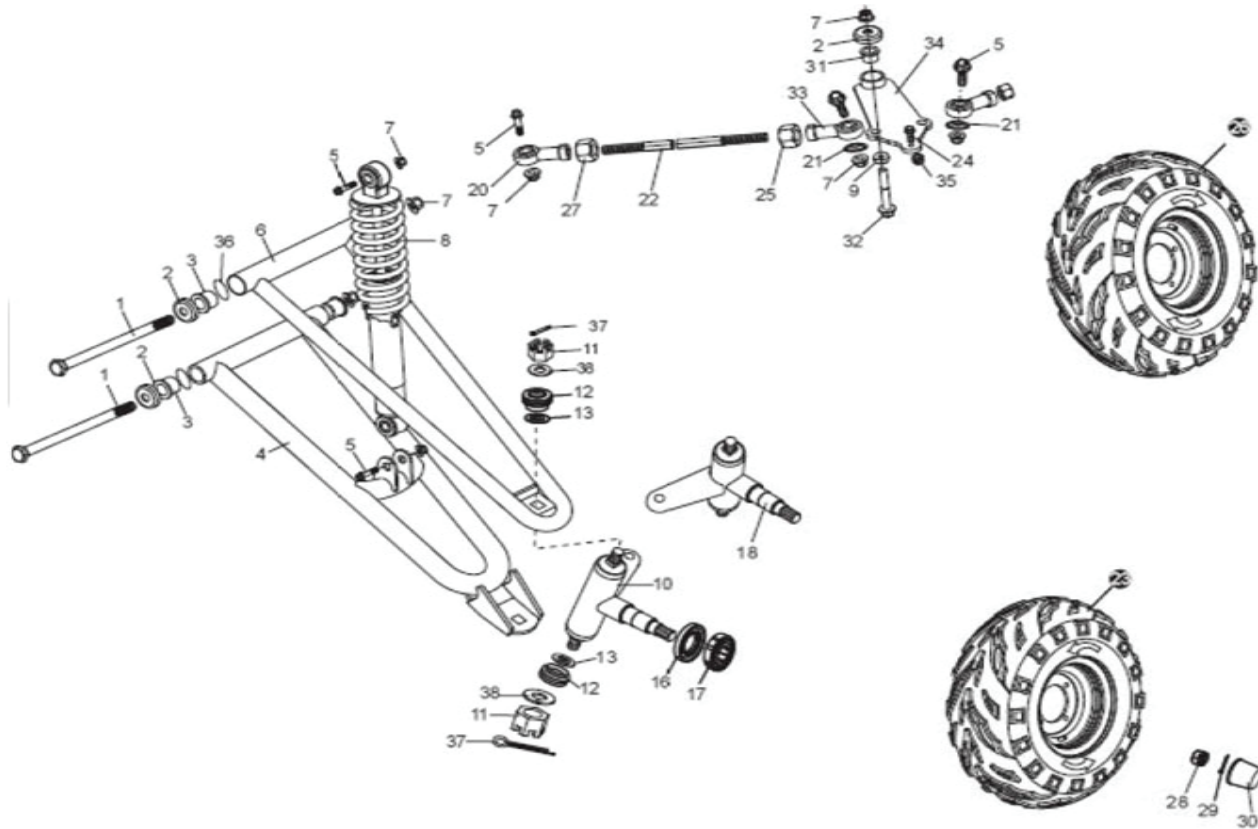

Ref. Num	PN	Description	Req. No.	Ref. Num	PN	Description	Req. No.
1	14450	Bolt, M10*1.25*232 hhcs	4	23	16-0901-00	Left Front Tire Assy, 16x6-8	1
2	14154	cap, Dust - Lower Suspension Arm	8	24	14430	Bolt, M6 x 1 x 25	2
3	14155	Bushing, A Arm Lower	8	25	14553	Nut, Tie Rod - M10 x 1.5	2
4	14391	Lower A-Arm	2	26	16-0903-00	Right Front Tire Assy, 16x6-8	1
5	14246	Bolt, M10 x 1.25 x 40 FHCS	8	27	14554	Nut, Tie Rod - M10 x 1.5	2
6	14392	Upper A-Arm	2	28	14224	Nt, M12 x 1.25 Castle Zn	2
7	12243	Nut, M10x1.25 Locking Flange	8	29	14150	Pin, M2 x 20 Cotter	2
8	14393	Shock, 345 mm Front	2	30	14151	Cap, Hub Nose	2
9	14087	Washer, Concave Clamp	2	31	14555	Bushing, 21 x 15 x 15	2
10	16-1502-L	Asm, Strut / Spindle- LH - Black	1	32	14448	Bolt, M10 x 1.25 x 85 HHCS	1
11	14244	Nut, M12 x 1.25 Castle ZN	4	33	14556	End, Tie Rod - M10 x 1.5	2
12	14137	Seal, ball Join	4	34	14400	Rivot, Steering Link	1
13	14138	Spacer, Ball join Head	4	35	14236	Nut, M6 x 1 - Nyloc Flange	2
16	14626	Bearing, 6201	1	36	14156	O-Ring, M21.2 x 2.65	8
17	14624	Bearing, Inner 6003Z	1	37	14490	Pin, M 1.8 x 20 Cotter	4
18	16-1502-R	Asm, Struct / Spindle - RH - Black	1	38	14245	Washer, M 12 Split Lock Zn	4
20	14529	End, Tie Rod - M10	2	39	002-1000837	8 x 3.75 steel wheel	2
21	14551	Washer	8	40	001-160608-00	16x6-8(F978) Tire	2
22	14552	Tie Rod, 360 x M10 x 1.5	2				

Rear Swing Arm Assembly

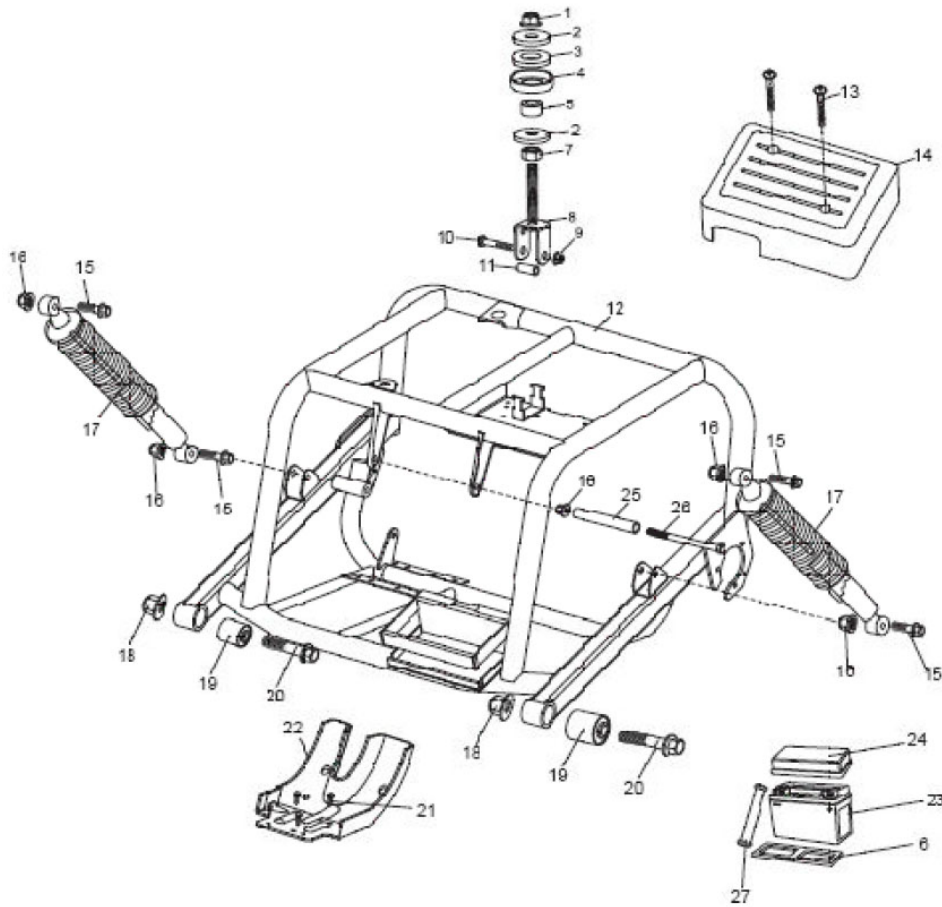

Ref. Num	PN	Description	Req. No.
1	9.220.012	Locking Flange Nut M12	1
2	8.010.042	Engine Mount Washer Lint	2
3	7.020.001	Engine Mount Cushion	1
4	8.020.045	Engine Mount Spacker	1
5	8.010.041	Engine Mount Collar	1
6	7.020.020	Battery Cushion	1
7	9.200.012	M12	1
8	6.000.026	Engine Mount	1
9	9.220.010	Lockign Flange Nut M10	1
10	9.110.045	Flange Bolt, M10x.1.25x45	1
11	8.010.076	Engine Mount Bolt Plate Collar	1
12	17-0602-00	Swing Arm	1
13	14431	M6X1X60	2
14	14172	electric box cover	1
15	14246	M10x1.25X40	4
16	14243	M10x1.25	5
17	14535	Rear Shock	2
18	14324	M12x1.25	2
19	14191	Bushing, swingarm isolator	2
20	14452	M12X1.25X60	2
21	14372	M6X1X16	4
22	14185	Guard, lower Chain	1
23	6.00.085	Battery	1
24	14186	Battery Cover	1
25	14177	Engine Mount, Spanner	1
26	14449	M10x1.25X195	1
27	14187	Battery Strap	1

Engine / Air Cleaner / Muffler

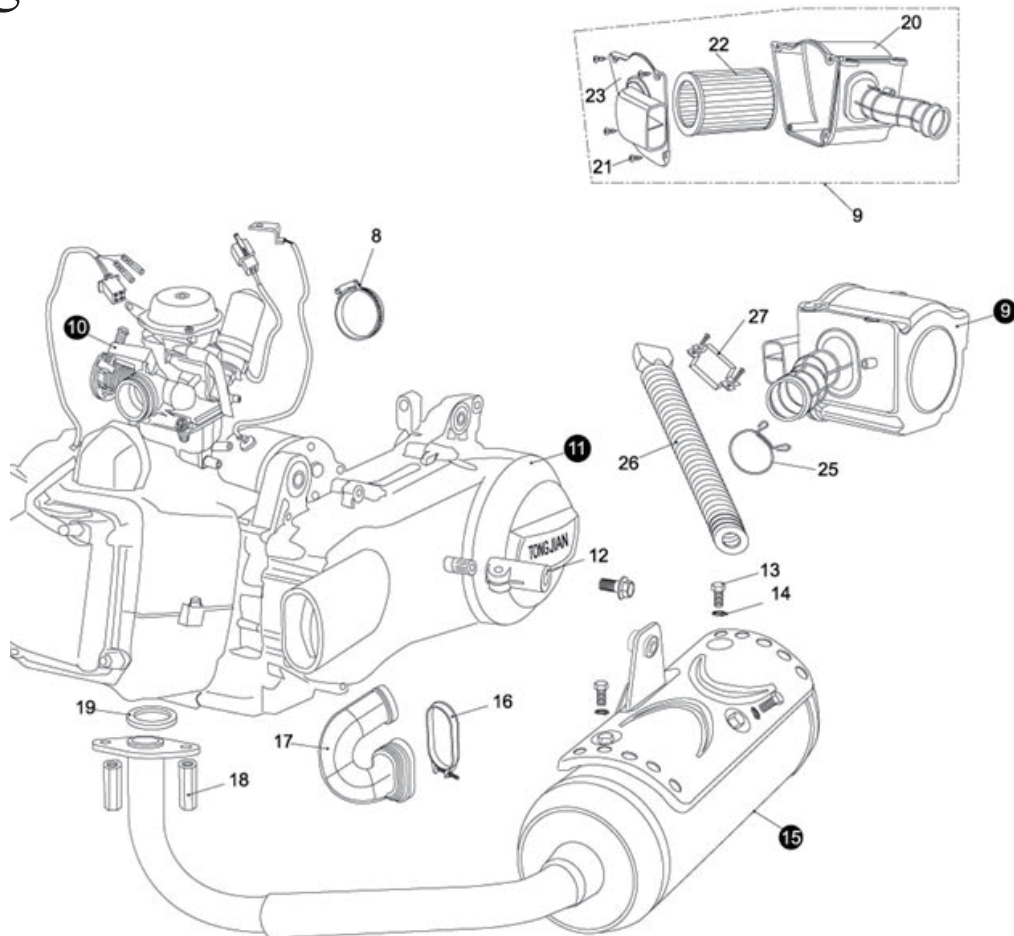

Ref. Num	PN	Description	Req. No.
8	8.020.056	AIR CLEANER CLAMP	1
9	4.000.018	AIR CLEANER ASSY.	1
10	6.000.024	CARBURETOR	1
11	006-HS150-00	ENGINE, 150CC	1
12	8.030.037	MUFFLER RACK SUPPORT	1
13	9.100.612	BOLT, M5X16	3
14	9.400.006	LOCKING WASHER Φ6	3
15	6.000.074	MUFFLER COMP. EX	1
16	8.020.055	BOOT CLAMP	1
17	6.000.162	SIDE CASE BOOT	1
18	9.040.027	MUFFLER JOINT NUT, M6	2
19	9.040.005	EX. PIPE GASKET	1
20	7.010.047	AIR CLEANER CASE COMP	1
21	9.805.003	TAPPING SCREW, M5X16	4
22	6.000.151	AIR CLEANER ELEMENT	1
23	7.010.048	AIR CLEANER COVER	1
25	8.040.013	AIR CLEANER CLIP	1
26	7.010.057	AIR CLEANER DUCT	1
27	8.020.176	AIR CLEANER CLAMP	1
28	9.108.040	FLANGE BOLT, M8X1.25X40	1

Electrical / Wiring Harness

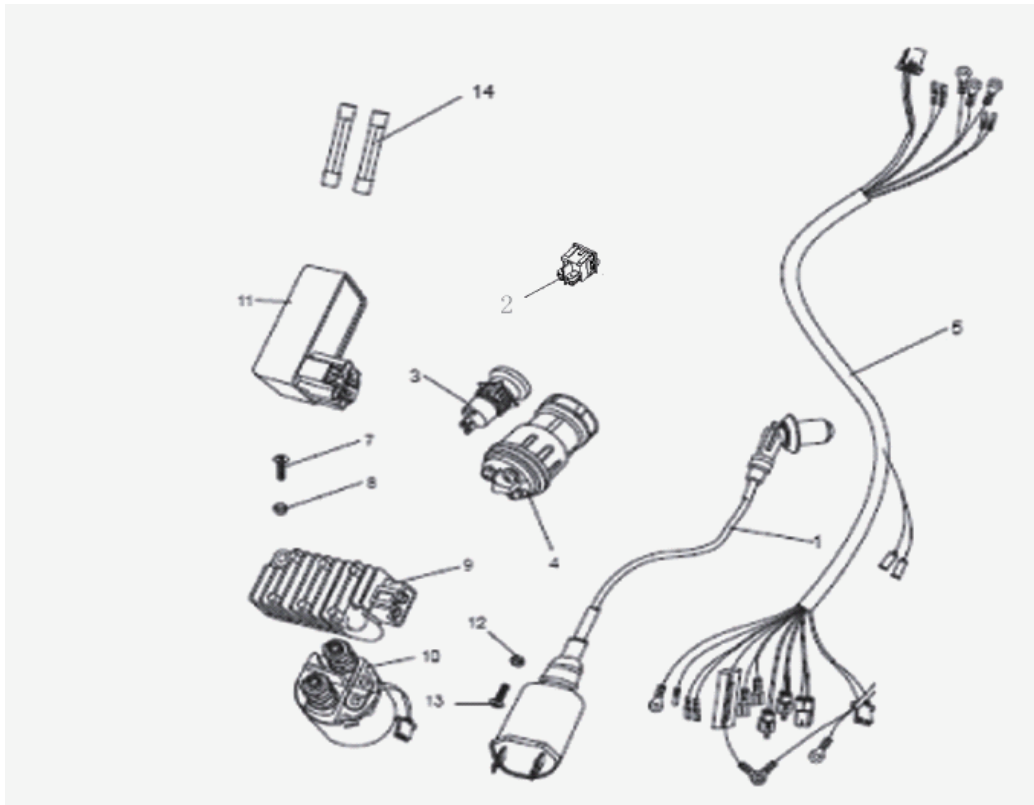

Ref. Num	PN	Description	Req. No.
1	6.000.025	Ignition Coil	1
2	6.000.058	Headlight Switch	1
3	6.000.159	Engine Shut Off Switch	1
4	17-0301-00	Ignition Switch	1
5	17-0303-00	Warning Harness	1
6	9.100.620	Bolt M6x20	2
7	9.210.006	Nylon Locking Nut M6	2
8	6.000.124	Regulator Rectifier	1
9	6.000.035	Starter Relay	1
10	6.000.267	C.D.I	1
11	9.210.005	Nut, M5	1
12	9.600.525	Bolt, M5x25	1
13	6.000.038	Fuse	2

Rear Housing

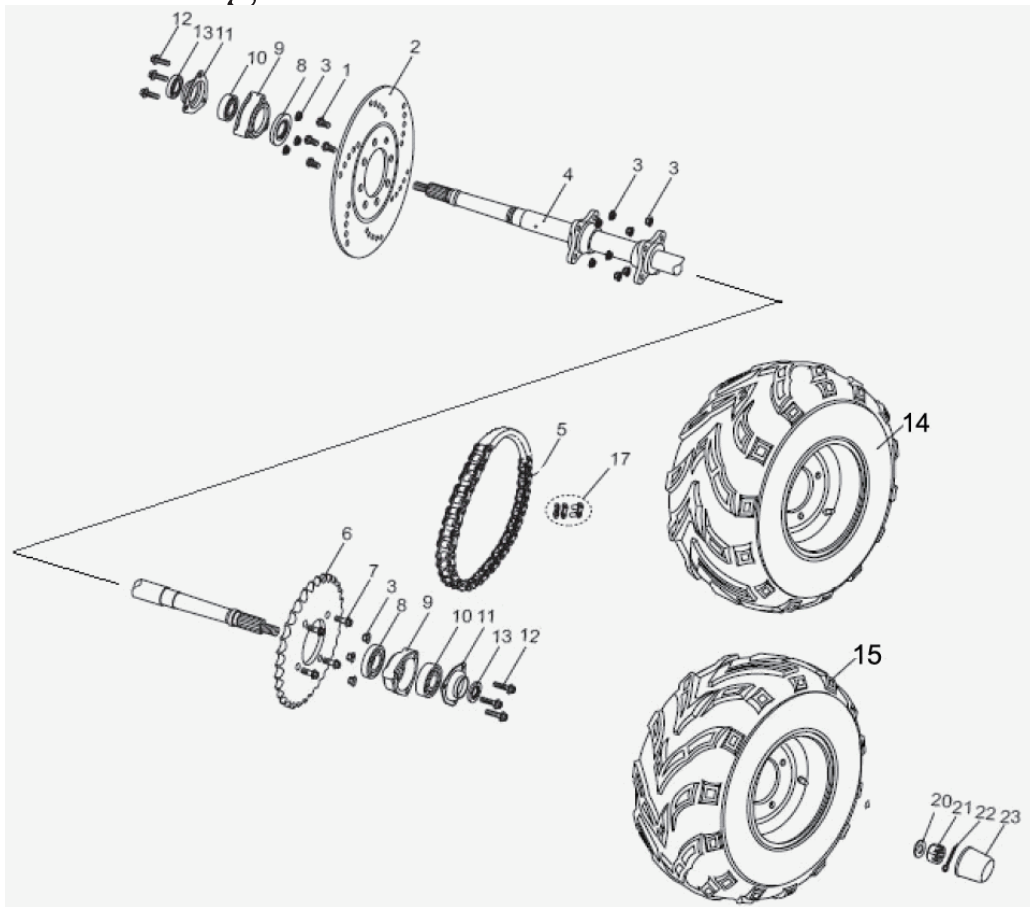

Ref. Num	PN	Description	Req. No.
1	9.108.022	Bolt M8x1.25x22	4
2	14202	Rear Brake Disc	1
3	9.220.008	Locking Flange Nut. M8	14
4	17-1101-00	Rear Axle	1
5	17-1103-00	Chain: 530H-50L	1
6	008-32-530	530H-32T	1
7	9.108.027	Bolt, M8x1.25x27	4
8	9.040.006	Dust Seal 50x34-7	2
9	8.030.008	Comp. Housing RR. Axle Brg	2
10	9.030.006	Bearing 6206	2
11	8.020.028	Bearing Base	2
12	9.108.040	Bolt, M8x1.25x40	6
13	9.040.007	Dust Seal 42 x30-7	2
14	17-0902-00	Left Rear Wheel Assembly: 18x7-8	1
15	17-0904-00	Right Rear Wheel Assembly: 18x7-8	1
17	6.000.149	Master Link, Chain	1
20	9.700.016	Spacer 16	2
21	9.800.016	Castle Nut, M16	2
22	9.500.430	Cotter Pin, 4x30	2
23	7.020.039	Cover RR. Hub	2
24	001-180708-00	Tire: 18x7-8	2
25	002-1000807	Steel Wheel: 8	2

Fenders / Shifter / Seat Belt

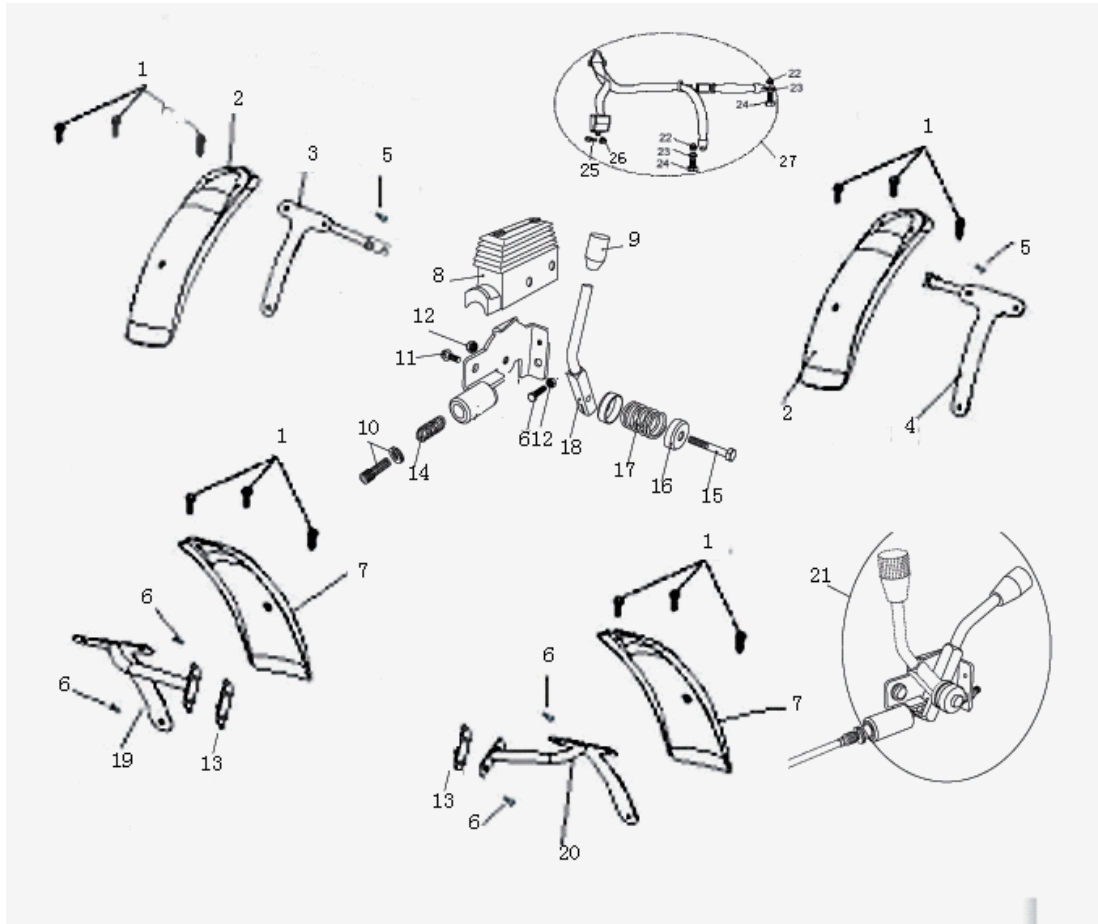

Ref. Num	PN	Description	Req. No.
1	9.106.014	Flange Bolt M6x14	12
2	17-0204.00	Rear Fender	2
3	17-0601-00L	Rear Fender Bracket, Driver Side	1
4	17-0601-00R	Rear Fender Bracket, Passenger Side	1
5	9.108.045	Flange Bolt M8x.125x45	2
6	9.108.025	M8X1.25X25	4
7	17-0211-00	Front Fender	2
8	7.020.024	Cover, Reverse Lever	1
9	7.020.026	Cover, Lever / Green Black	1
10	9.108.030	M8X1.25X30	1
11	9.108.020	M8X1.25X20	1
12	6.034.096	M8X1.25	6
13	17-0624-00	Fender Bracket Holder	2
14	8.040.004	Spring	1
15	9.108.040	M8X1.25X40	1
16	8.020.082	Spacer Lever	2
17	8.040.003	Spring, Lever	1
18	6.050.065	Lever	1
19	17-0625-00L	Front Left Fender Bracket	1
20	17-0625-00R	Front Right Fender Bracket	1
21	6.000.042	Reverse Lever Assy.	1
22	9.020.010	M10X1.25	4
23	9.110.030	M10	4
24	9.710.025	M10X1.25X25	4
25	9.112.025	M12X1.25X25	4
26	9.200.012	M12X1.25	4
27	14786	Retractable Seatbelt	2

Fuel Tank / Seats / Rear Carrier

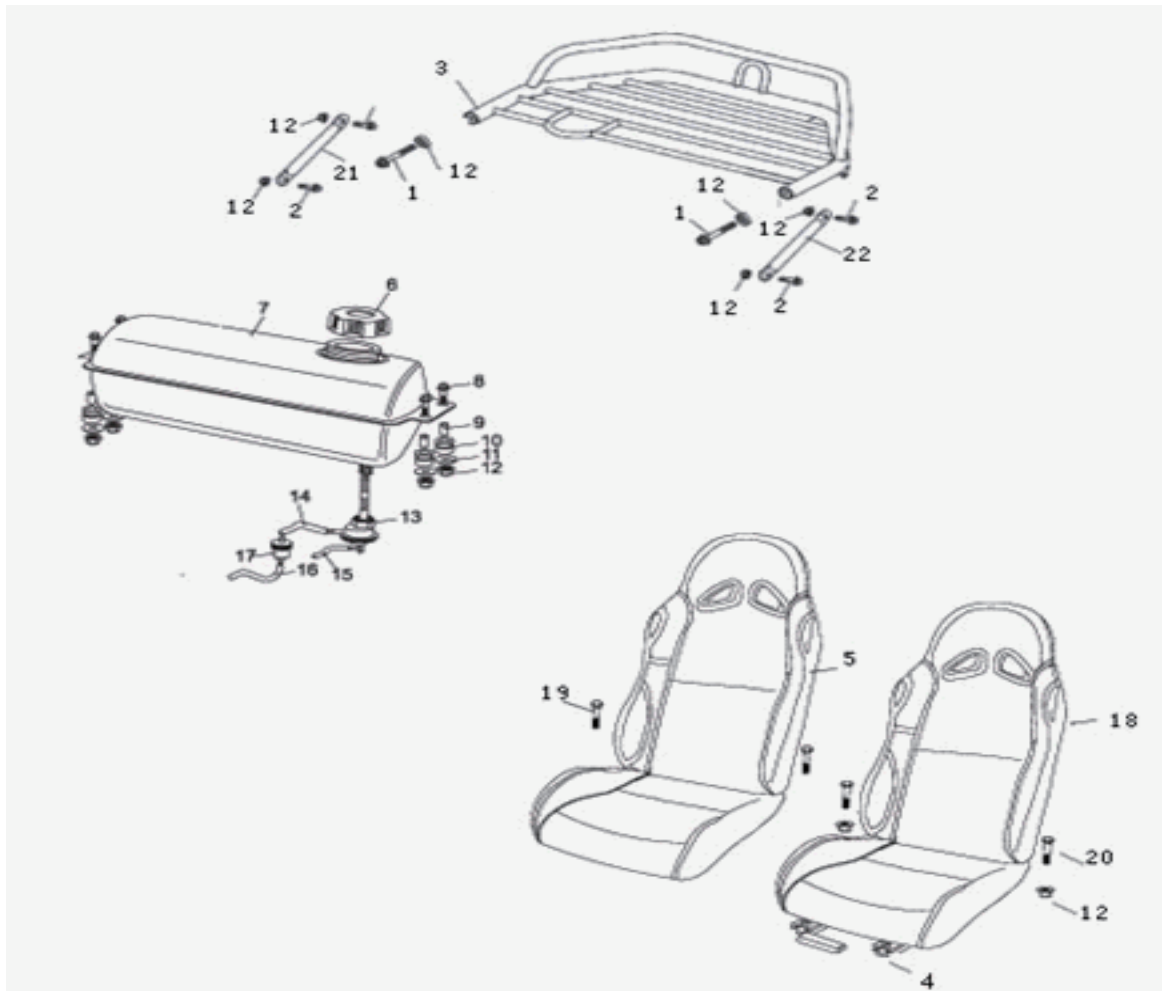

Ref. Num	PN	Description	Req. No.
1	9.108.030	M8X1.25X30	2
2	9.108.025	M8X1.25X25	4
3	17-0609-00	Rear Rack	1
4	16-0411-00	Driver Seat Track	1
5	16-0412-00	Passenger Seat	1
6	6.000.053	Fuel Cap	1
7	4.000.011	Fuel Tank	1
8	9.108.045	M8X1.25X45	4
9	8.010.034	Tank Collar	4
10	7.020.005	Rubber Mount	4
11	9.300.008	Washer, M8	4
12	9.210.008	Nut, M8x1.25	12
13	6.000.046	Auto Fuel Cock Assy.	1
14	7.020.021	Fuel Tube Comp #1	1
15	7.020.023	Vacuum Tube Comp	1
16	7.020.022	Vacuum Tube Comp. #2	1
17	6.000.056	Fuel Filter	1
18	16-0401-00	Driver Seat	1
19	9.108.050	M8X1.25X50	2
20	9.108.040	M8X1.25X40	2